

4.0 ELECTRICAL

4.6 TYPICAL WIRING SCHEMATIC (50Hz)

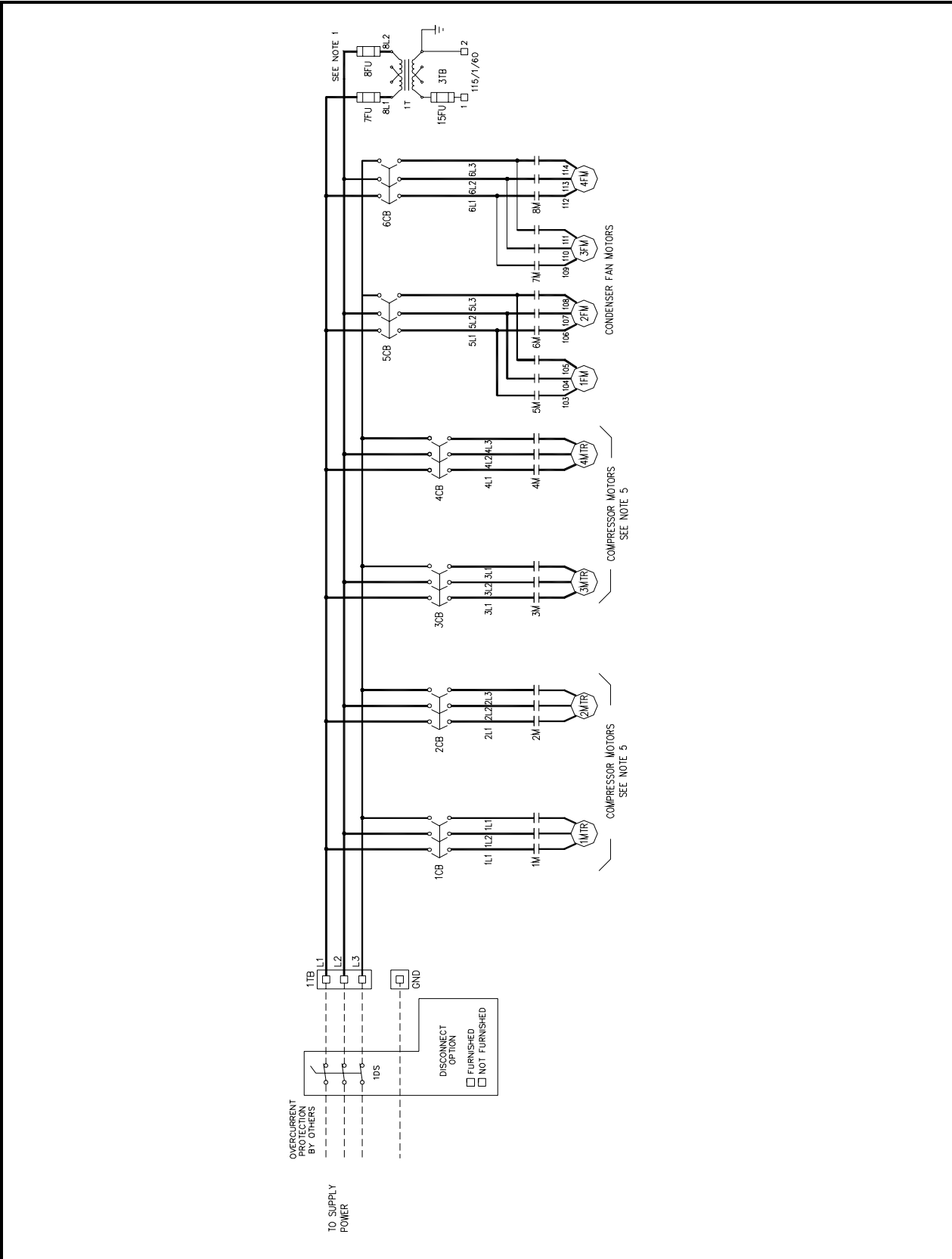

4.0 ELECTRICAL

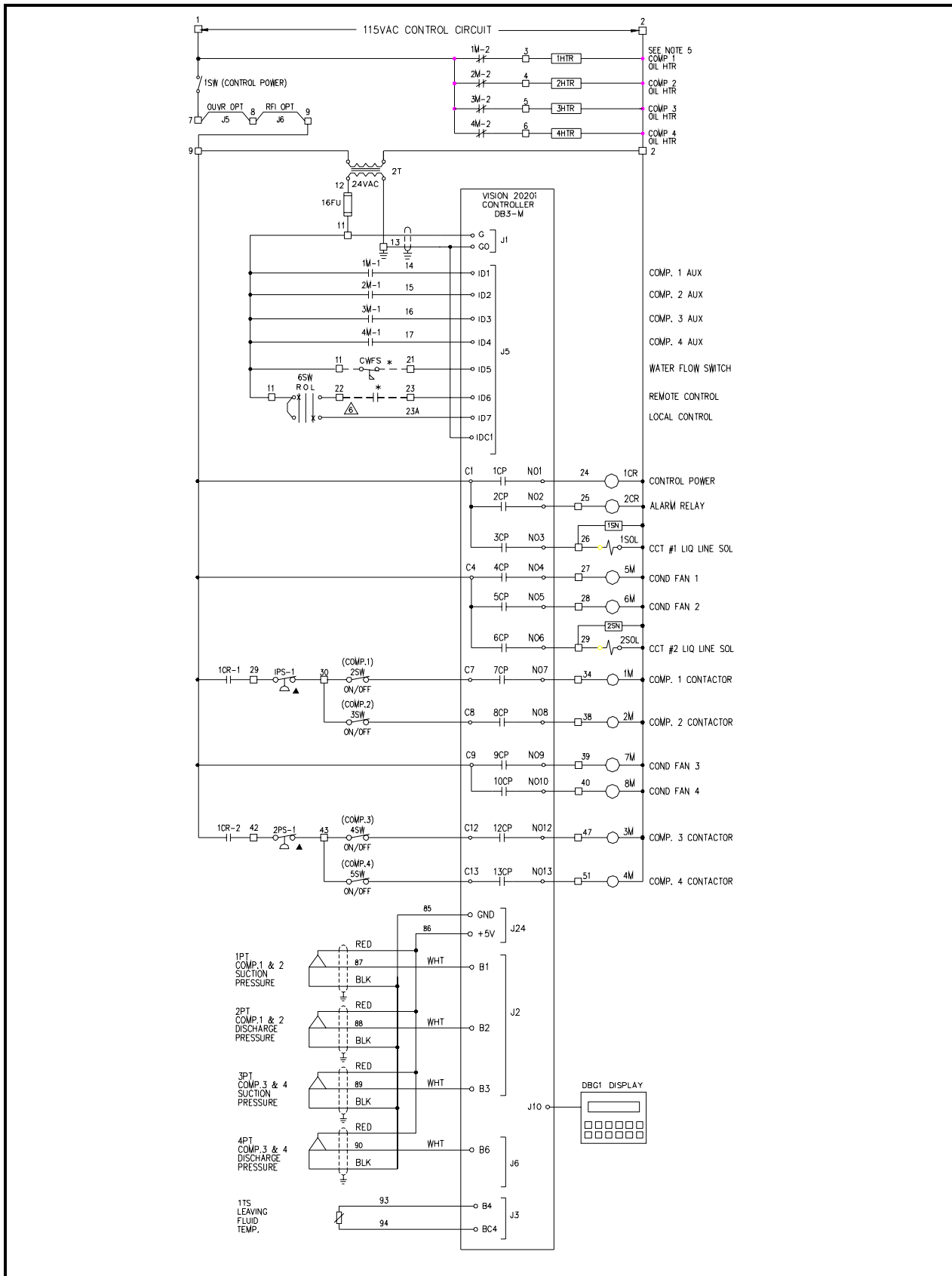

4.0 ELECTRICAL

