

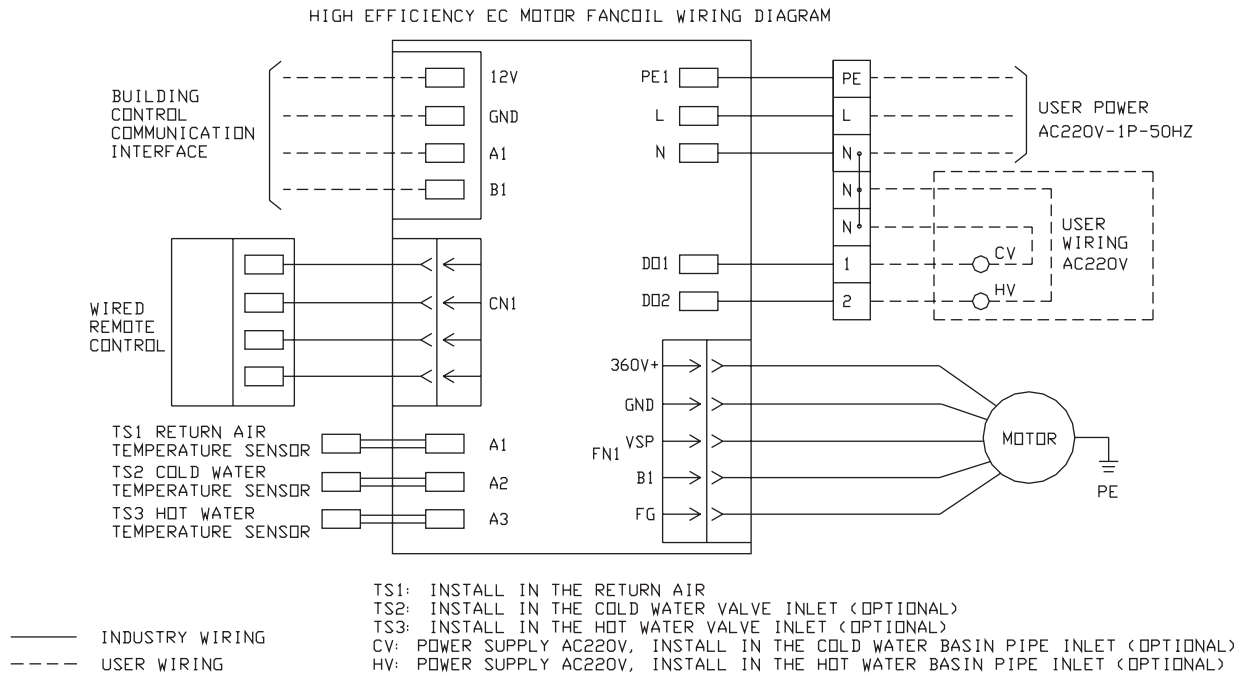

# ELECTRICAL DIAGRAM



- KC -Ceiling concealed (static pressure 12Pa)
- KCO - Ceiling concealed with back return air plenum (static pressure 0Pa)
- KCOC - Ceiling concealed with bottom return air plenum (static pressure 0Pa)
- GC - Ceiling concealed (static pressure 30Pa)
- GCO - Ceiling concealed with back return air plenum (static pressure 20Pa)
- GCOC - Ceiling concealed with bottom return air plenum (static pressure 20Pa)
- GCR - Ceiling concealed (static pressure 50Pa)
- GCROC - Ceiling concealed with bottom return air plenum (static pressure 40Pa)
- GCY - Ceiling concealed (static pressure 70Pa)
- GCYO - Ceiling concealed with back return air plenum (static pressure 60Pa)
- GCYOC - Ceiling concealed with bottom return air plenum (static pressure 60Pa)