



INSTALLATION, OPERATION &
MAINTENANCE MANUAL

INSTALLATION INSTRUCTIONS

Air Handler Unit

Fixed frequency 1.5-2-2.5-3-3.5-4-5Tons

Frequency conversion 2-3-4-5 Tons

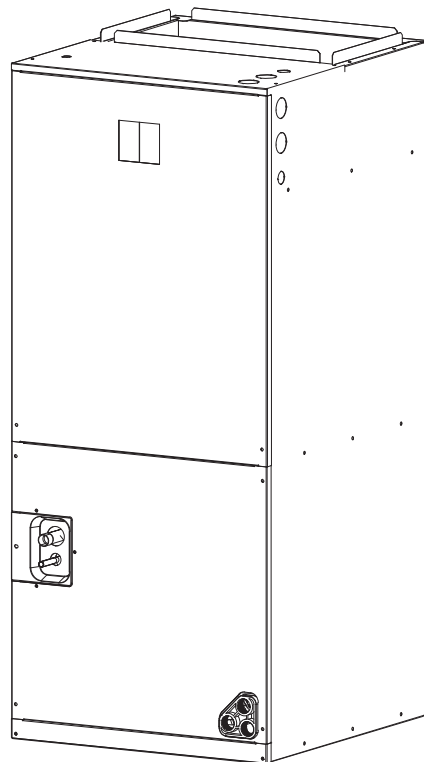

19 SEER

DC Inverter

208V 60Hz

CONTENTS

1. Symbol and Key to Safety Instructions.....	01
2. General.....	03
3. Application	09
4. Electrical Wiring.....	13
5. Airflow Performance	17
6. Piping System	21
7. Refrigerant Pipe Connection	22
8. Air Filter (Not Factory Installed).....	24
9. Installation Size of Filter Screen.....	25
10. Maintenance	26
11. Wiring Diagram	27

1. Symbol and Key to Safety Instructions

1.1 Symbol Keywords



WARNING

The warnings in this document are identified by warning triangles printed on a gray background. The keyword at the beginning of the warning indicates the type and severity of the risk if no measures are taken to prevent it.

The following keywords are defined and used in this document:



Dangerous

means a Hazardous situation, which, if not avoided, will lead to death or serious injury.



Warning

Indicates a Hazardous situation, which may lead to death or serious injury if not avoided.



Caution

Indicates a Hazardous situation, which may cause mild to moderate injury if not avoided.



Note

Used to deal with behaviors unrelated to personal injury.

Important Information



This symbol represents important information that is not harmful to people or property.

1.2 Safety

Please Read Before Continuing.

Warning:



- The unit must be installed by qualified personnel with a capacity certificated for handling refrigerant fluids. Refer to regulation and laws in use on installation location.
- This appliance is not intended for use by persons (including children) with reduced physical, sensory or mental capabilities, or lack of experience and knowledge, unless they have been given supervision or instruction concerning use of the appliance by a person responsible for their safety.
- The appliance shall be installed in accordance with national wiring regulations.
- Children should be supervised to ensure that they do not play with the appliance.
- The minimum clearance to combustible surfaces (curtains,blinds,etc.) from the appliance should be 300 mm.
- Before accessing the connection terminals, all power circuits must be disconnected.
- Please read these instructions carefully before attempting to install or operate. Failure to follow these instructions may result in incorrect installation, adjustment, repair or maintenance, which may result in fire, electric shock, property damage, personal injury or death.



This document is property of customer and should be kept together with this equipment. These instructions do not cover all the different variations of the system, nor do they provide all the unexpected situations that may be encountered during the installation process.



Warning: Fire, electric shock, property damage, personal injury or death

- The whole installation process must comply with NATIONAL, STATE AND LOCAL CODES. If you need more information, please contact your local dealer.



Warning: Risk of electric shock

- Can cause injury or death, disconnect all remote electric power. More than one disconnect switch may be required to cut off the power of the equipment. Dangerous voltage can cause serious personal injury or death.
-



Warning: Electric shock

- If the fan assembly needs to be dismantled, all disconnect switches supplying power to the equipment must be powered off and locked (if the device cannot be seen), so that the field power cord can be safely dismantled from the fan assembly. Otherwise, it may cause electric shock, personal injury or death.
-



Warning: Fire, electric shock, property damage, personal injury or death

- Due to possible equipment damage or personal injury, installation, repair and maintenance should be carried out by trained qualified maintenance personnel. Consumers are advised to only clean/replace the filter screen. Do not operate the equipment with the access panel removed.
-



Warning:

- This product may expose you to chemicals including lead and lead components, which are known to cause cancer, birth defects or other reproductive harm in California. For more information, please visit www.P65Warnings.ca.gov.
-



Warning: Electric shock

- The device must be permanently grounded. Otherwise, it will cause electric shock, personal injury or death.
-



Note: Fire risk

- The product is only used for one or two residences.
 - The materials of pressure ventilation system and piping system must meet the latest NFPA 90B standard.
-



Note:

- Make sure the fan bracket is fastened (3motor mounting bolts-Figure1). Then, before operating the device, check whether the wheels are firmly fixed on the motor shaft.
-

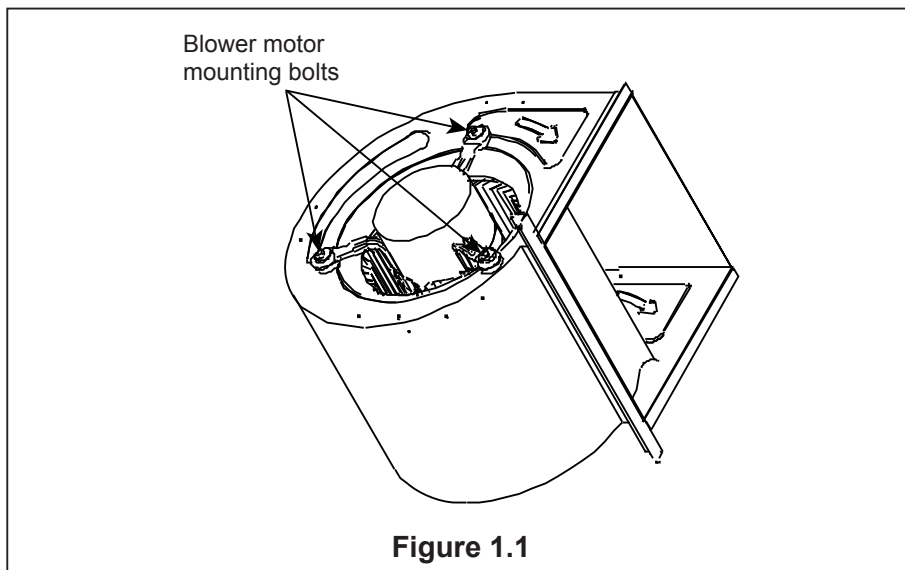

2. General

The device can return air at the bottom at the upward airflow position, return air from left to right at the horizontal position and return air at the top at the downward airflow position.

This air handler provides the flexibility to be installed in any upward, downward or horizontal airflow application. According to the airflow performance table in Section 5, adjust the fan speed gear through the DIP switch (located on the control panel of the air handler) to select the correct air volume. Please refer to the wiring diagram of Dip switch settings.

Please refer to Figure 8 for high and low voltage wiring.

To ensure proper installation, please choose a firm and flat site. Make sure enough clearance is reserved for installation and maintenance.

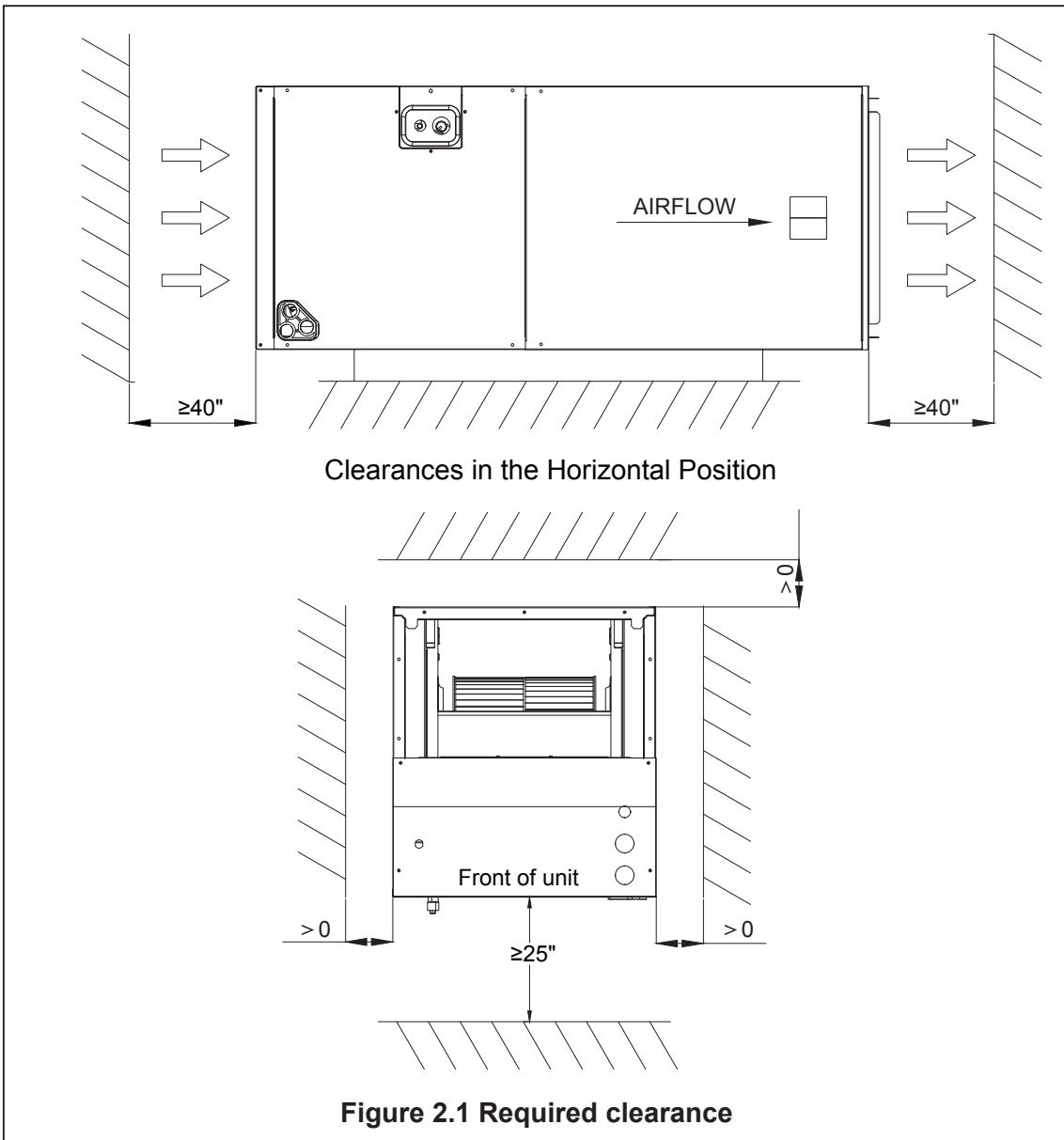

Note:



- As shown in Figure 2.1, the installed device must have the required clearance. Failure to follow these instructions may result in equipment damage and/or premature equipment failure.

Warning: Fire risk



- Keep flammable materials and vapors (such as gasoline) away from air handlers. Failure to follow these instructions may result in death, explosion or fire.

2.1 Installation in High Humidity Environment

When the unit is installed in a hot and humid place, if the temperature in the installation space exceeds 86 °F and the RH (relative humidity) exceeds 80%, it is recommended to insulate the outside of the cabinet. Use glass wool or polyethylene foam as insulation material; The thickness should be greater than 2 inches, and it must be suitable for the installation space opening.

Condensate may also be produced on the insulation surface. Ensure that insulation materials designed for HVAC systems are used. In the process of refrigeration, condensate may be produced on the surface. It is also recommended to use an auxiliary drain pan and fix the equipment firmly to prevent it from falling. See Figure 2.2, 2.3, 2.4 and 2.5.



For the use of auxiliary drainage tray, please refer to local regulations.

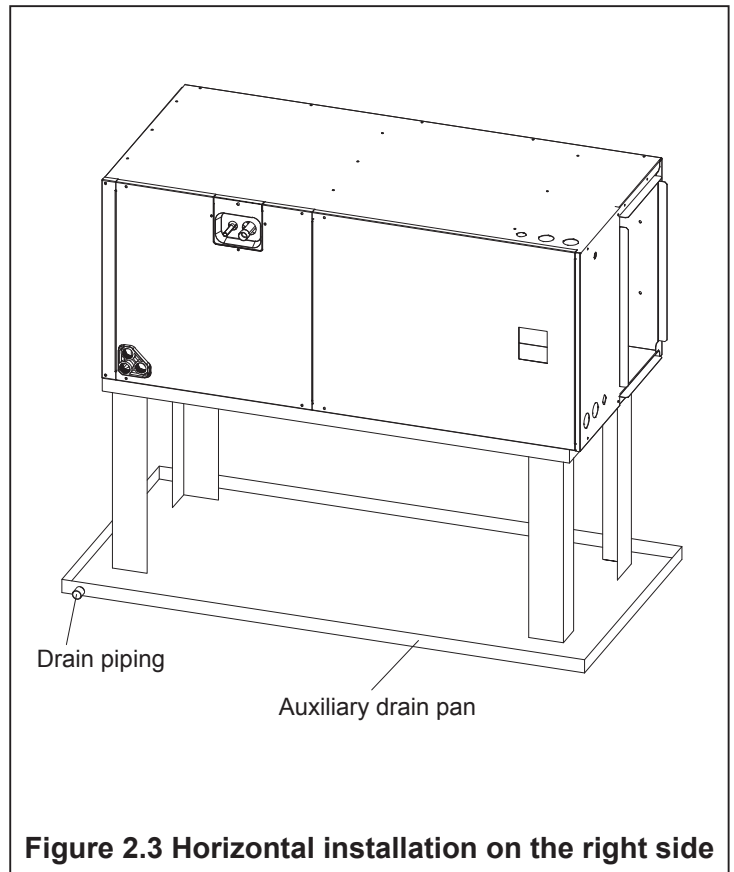
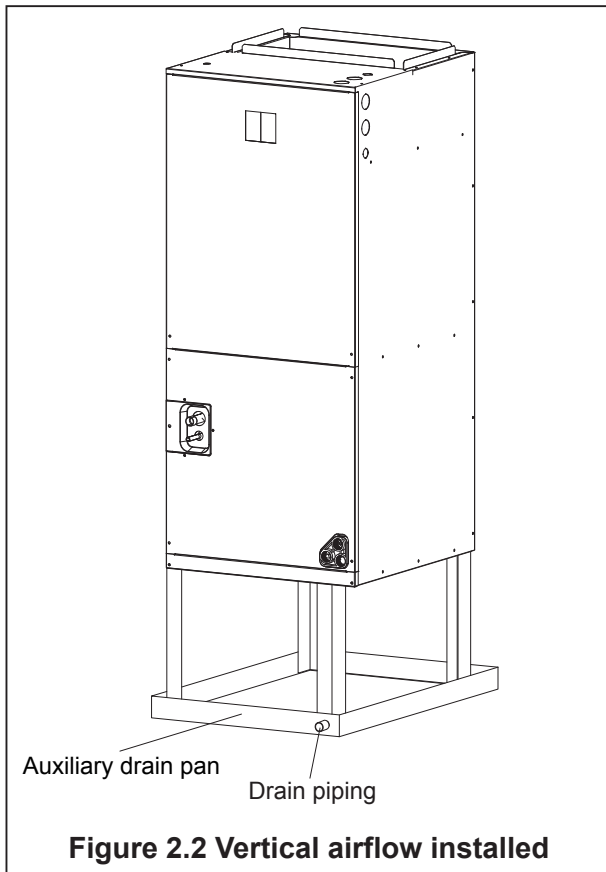

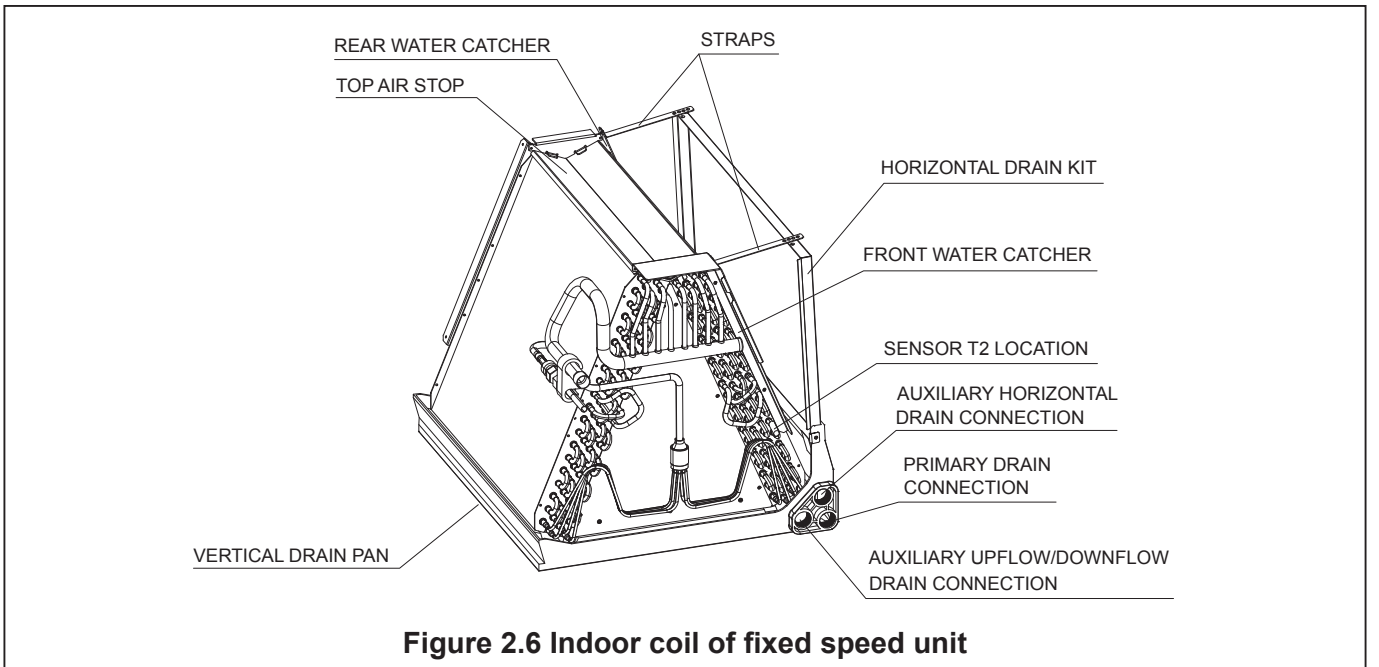
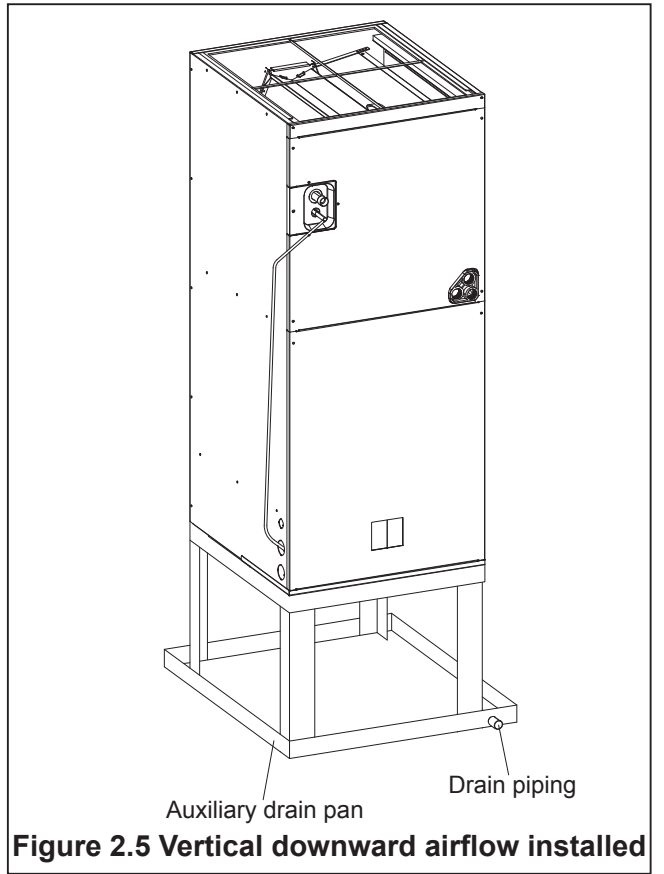
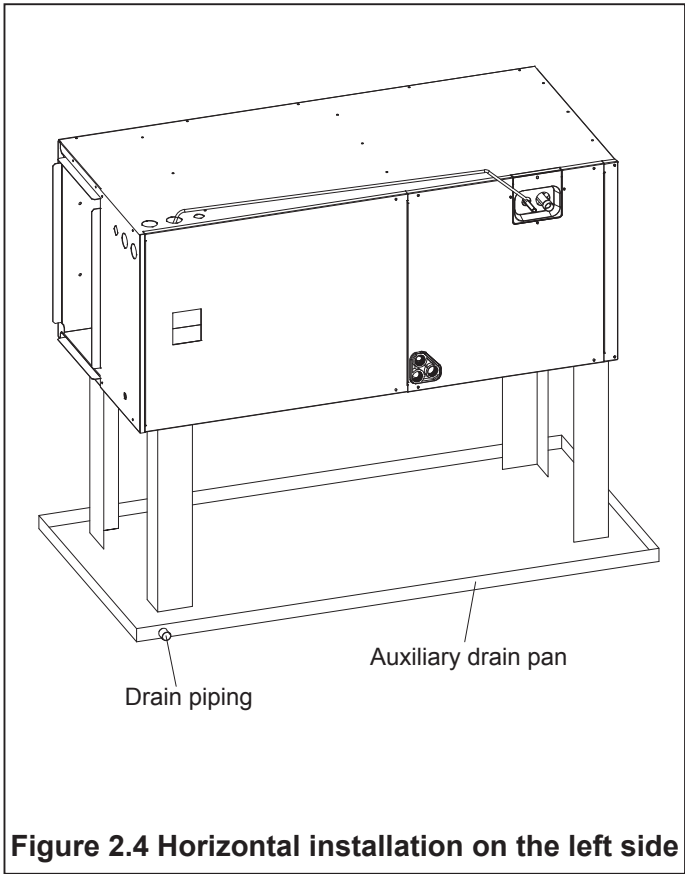

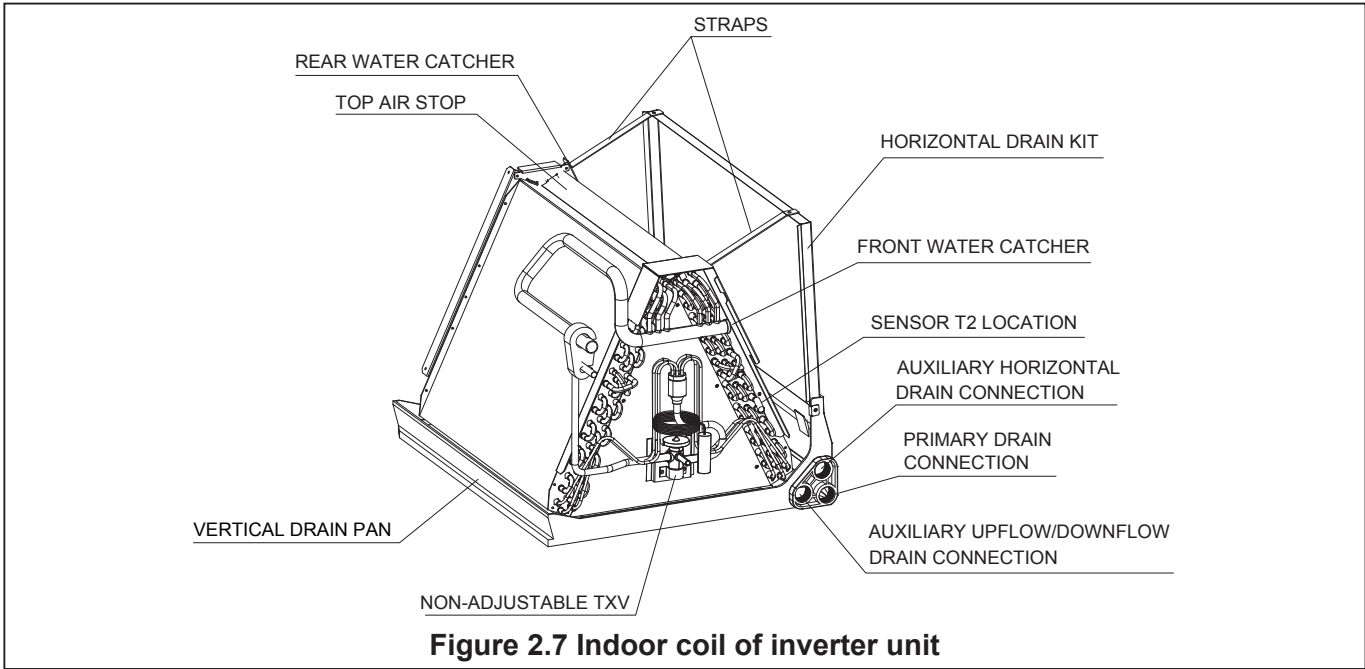

2.2 Unit Dimension



The front of the unit requires a clearance of 25 inches for the maintenance of filters and coils.

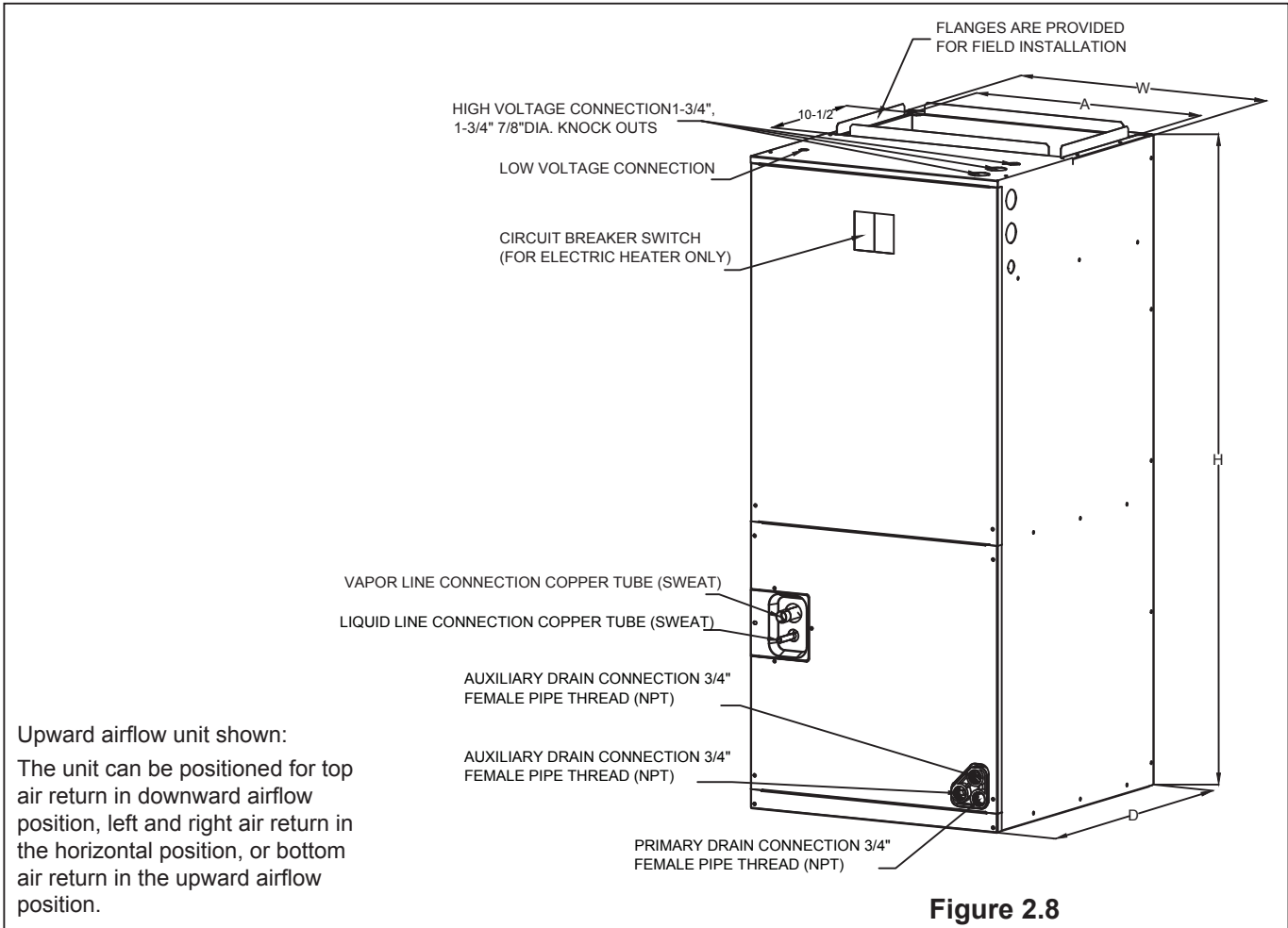

Upward airflow unit shown:
 The unit can be positioned for top air return in downward airflow position, left and right air return in the horizontal position, or bottom air return in the upward airflow position.

Table 2.1 Unit Dimension

Model	Dimension Inches [mm]				
	Height "H"	Width "W"	Dimension "D"	Air outlet "A"	Liquid Line / Vapor Line
24K	45-3/4 [1162]	19-5/8 [500]	22 [560]	17-7/8 [454]	3/8 / 3/4 [9.5]/[19]
36K	45-3/4 [1162]	19-5/8 [500]	22 [560]	17-7/8 [454]	3/8 / 3/4 [9.5]/[19]
48K	53-1/8 [1350]	22 [560]	24 -1/2[623]	19-1/2 [496]	3/8 / 7/8 [9.5]/[22]
60K	53-1/8 [1350]	22 [560]	24 -1/2[623]	19-1/2 [496]	3/8 / 7/8 [9.5]/[22]

Table 2.2 Unit Dimension

Model	Dimension Inches [mm]				
	Height "H"	Width "W"	Dimension "D"	Air outlet "A"	Liquid Line / Vapor Line
18K	45-3/4 [1162]	19-5/8 [500]	22 [560]	17-7/8 [454]	3/8 / 3/4 [9.5]/[19]
24K	45-3/4 [1162]	19-5/8 [500]	22 [560]	17-7/8 [454]	3/8 / 3/4 [9.5]/[19]
30K	45-3/4 [1162]	19-5/8 [500]	22 [560]	17-7/8 [454]	3/8 / 3/4 [9.5]/[19]
36K	45-3/4 [1162]	19-5/8 [500]	22 [560]	17-7/8 [454]	3/8 / 3/4 [9.5]/[19]
42K	45-3/4 [1162]	19-5/8 [500]	22 [560]	17-7/8 [454]	3/8 / 3/4 [9.5]/[19]
48K	53-1/8 [1350]	22 [560]	24 -1/2[623]	19-1/2 [496]	3/8 / 7/8 [9.5]/[22]
60K	53-1/8 [1350]	22 [560]	24 -1/2[623]	19-1/2 [496]	3/8 / 7/8 [9.5]/[22]

3. Application

3.1 Vertical Upward Airflow

- The vertical upward outlet configuration is the factory default configuration of all models (see Figure 2.8).
- If the return air is to be ducted, the duct should be installed flush with the ground. Use 1/8 to 1/4 inch thick fireproof elastic gasket between ducts, unit and floor.



Torque applied to the drainage connection should not exceed 15 foot pounds. For vertical upward air flow and horizontal right installation, dimensions of refrigerant and drain pipe can be found in Figure 3.1.

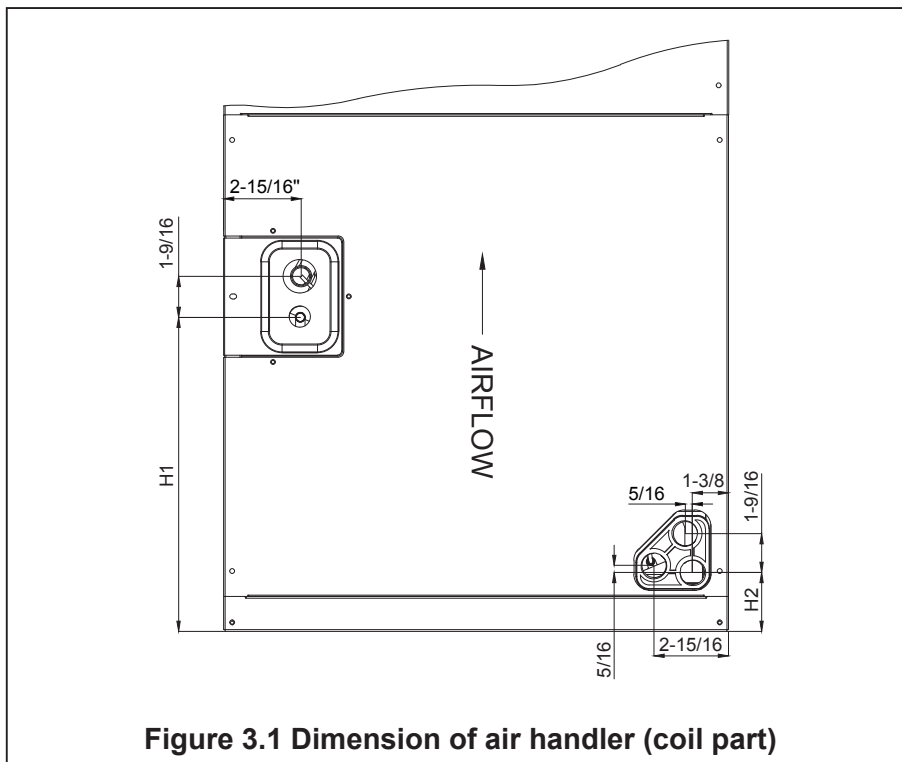

Table 3.1

Model	"H1" inch [mm]	"H2" inch [mm]
18K/24K/30K/36K/42K	12-1/4 [311]	2-1/4[57]
48K/60K	19[483]	1-25/32[45]

3.2 Vertical Downward Airflow

Convert to Vertical Downward air flow Position:

The vertical upward airflow position can be converted into the vertical downward airflow position. Remove the coil (evaporator) access panel and coil, and reinstall it by rotating 180 ° from the original position. See Figure 3.2 and 3.3.

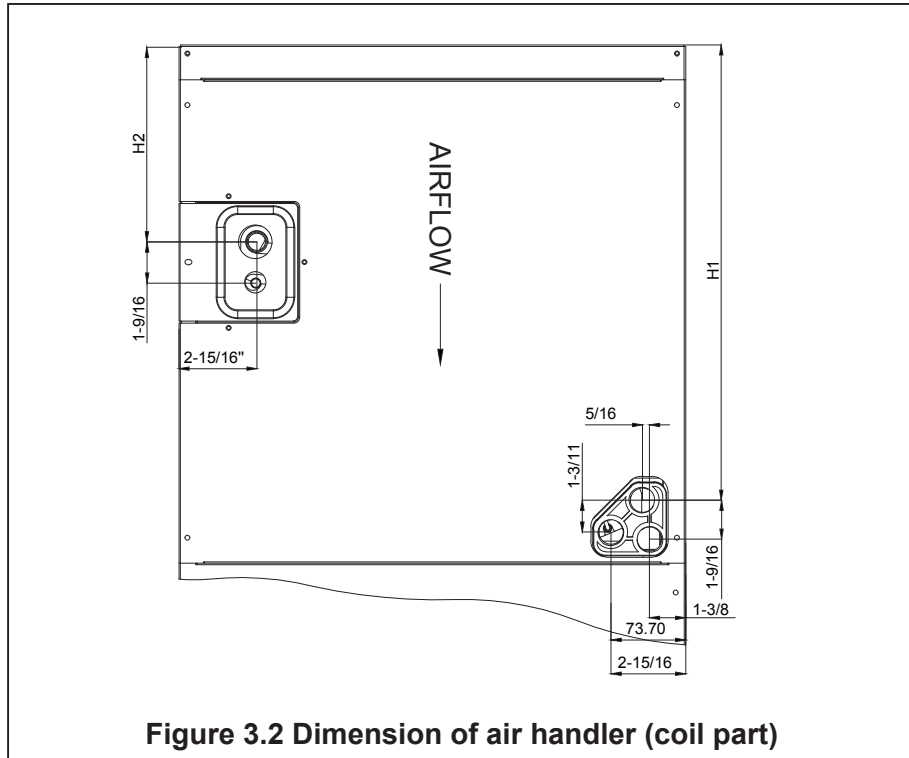

Figure 3.2 Dimension of air handler (coil part)

Table 3.2

Model	"H1" inch [mm]	"H2" inch [mm]
18K/24K/30K/36K/42K	17-11/16 [449]	7-9/16 [192]
48K/60K	21-11/16 [551]	4-13/32 [112]

3.3 Horizontal

Horizontal Horizontal right installation is the default factory configuration for all models.

Switch to Horizontal Left Installation:

- By removing the indoor coil assembly and reinstalling the coil, the vertical upflow position can be converted into a horizontal left position, See Figure 3.2.
- Rotate the device by 90° to the horizontal left position, with the coil segment on the right and the blower segment on the left.
- Re-install the indoor coil by rotating 180° from the original position. Ensure that the fixing groove is fully engaged with the coil guide rail. See figs. 3.2 and 3.3.
- When configured to be placed horizontally above the ceiling and/or living space, it is recommended to use an additional field supplied drain pan.

Steps to Change Cabinet Direction to Vertical Downward or Horizontal Left Direction

1. Remove the screws and the front panel, and disconnect the plug of T2 sensor wire from the circuit board (Figure 3.3, Step 1).
2. Pull out the coil with sensor wire (do not disconnect T2 sensor from the liquid pipe of the coil). Pull the sensor wire out of the liquid pipe hole on the cabinet cover (see 2A in Step 2 of Figure 3.3).
3. Install the coil in the correct direction and fix it in place. Remove the knock-down hole on the side of the cabinet (Step 3 labeled 3A in Figure 3.3), connect the plug end of the sensor wire to the control board (pass the wire through the knock-down hole in the cabinet), and seal it properly. (Figure 3.3, step 3).

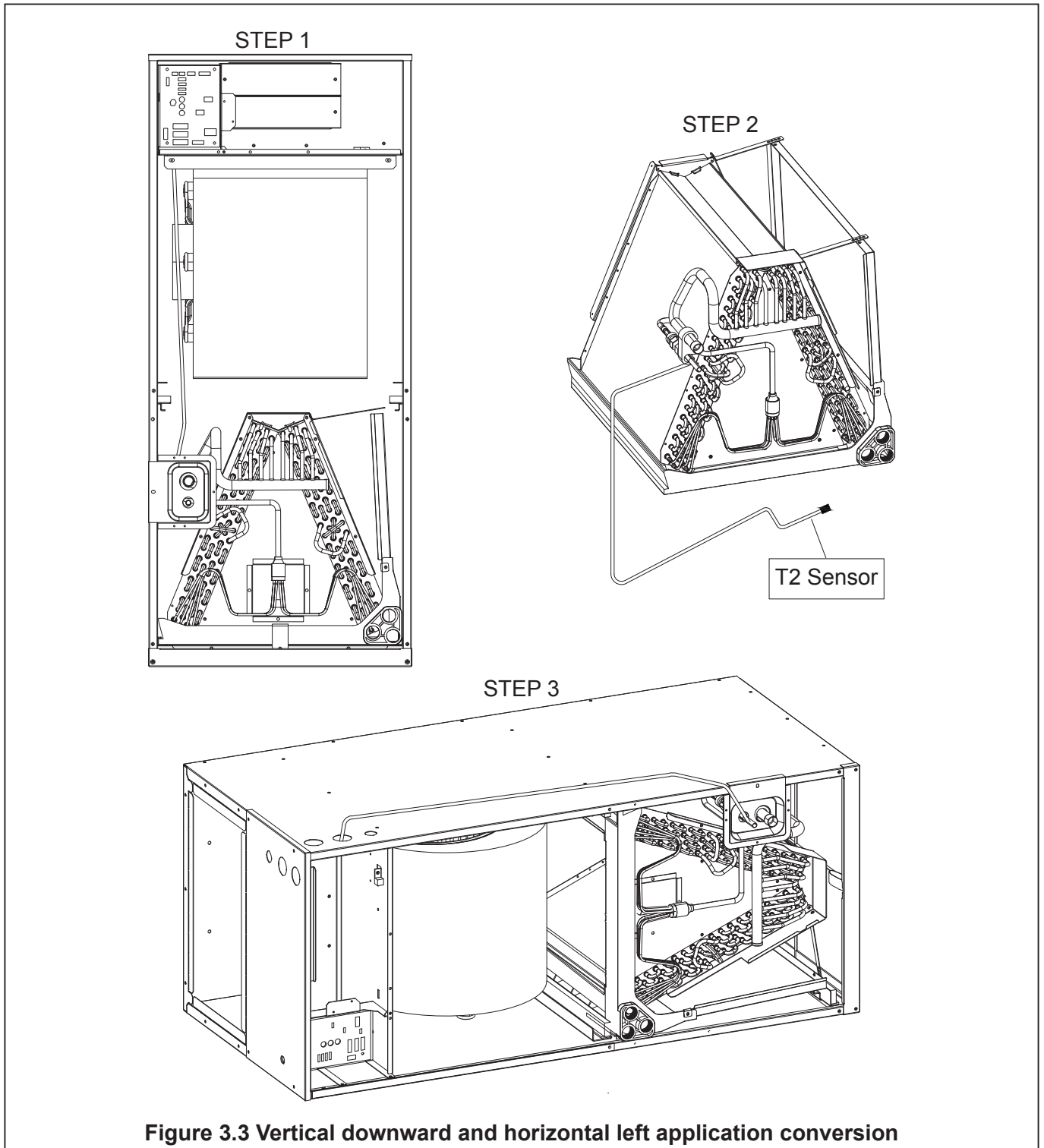

Figure 3.3 Vertical downward and horizontal left application conversion

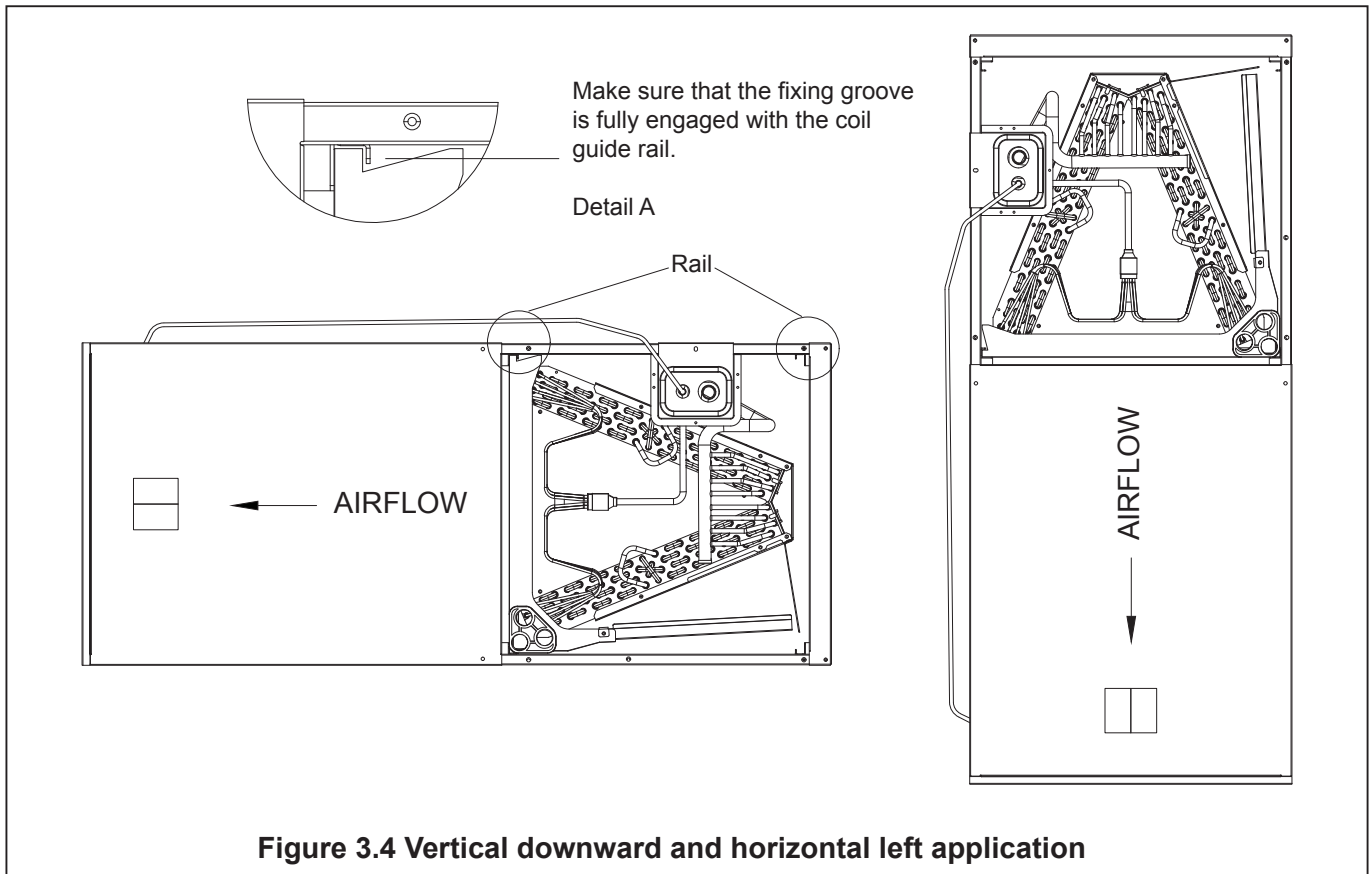

Figure 3.4 Vertical downward and horizontal left application

Note:



- The horizontal installation application must be configured as right hand air outlet or left hand air outlet the horizontal drain pan must be located under the indoor coil. Failure to use the drain pan will result in property damage.

Horizontal Conversion:

Remove the indoor coil and reinstall it by 180 ° from the original position. The horizontal right air outlet can be changed to the horizontal left air outlet.

3.4 Install in unconditioned space.

Note:



- There are two pairs of coil guides in the air handler, which are used for upward and downward air outlet applications. If the air handler is installed in an unconditioned space, two unused coil tracks should be removed to minimize condensate on the surface of the air handler. Unscrew 6 mounting screws from both sides of the cabinet to easily remove the coil guide rail.

4. Electrical Wiring

The wiring on site must comply with the National Electric Code (C.E.C. in Canada) and any applicable local regulations.



Warning: Electric shock

- Before installation or maintenance, please disconnect all power supply of the device. More than one disconnect switch may be required to cut off the power of the equipment. Dangerous voltage can cause serious personal injury or death.

4.1 Power Supply Wiring

It is important to have a suitable power supply connected to the device being installed. For more detailed requirements, please refer to the device rating label, wiring diagram and electrical data in the installation instructions.

- If necessary, install a branch circuit breaker of sufficient size, which is located within sight and easy to install.



When installing an electric heater, the device may be equipped with one or two 30-60 amp circuit breakers. These circuit breakers protect internal lines and act as disconnecting devices when short circuit occurs. The circuit breaker installed in the device does not provide overcurrent protection for the power connection, so its size may be larger than that of the branch circuit protection.

-
- The power supply line of the circuit must be a minimum 221°F copper conductor. For current carrying capacity, wire size and circuit protector requirements, please refer to electrical data in this section. The power supply protection device can be a fuse or a "HACR" type circuit breaker.
 - High-voltage wires can pass through the tapping holes on the right, left or top of the device.
 - "Three 7/8", 1-3/8" and 1-3/4" diameter tapped holes can be used to connect high-voltage wires to the device.
 - The high-voltage wires must be connected to the red and black wires in the control part of the air handler.

4.2 Control Wiring



The low-voltage control line should not run in the conduit together with the high-voltage line. Keep the distance between the two catheters according to local codes.

-
- Scenes less than 100 feet in length should use 18 AWG colored low-voltage wires. 16 AWG wire should be used for scenes with a length of more than 100 feet.
 - See Figure 2.8 for the connection position of low-voltage wires.
 - For the correct wiring instructions, please refer to the wiring diagram located inside the air handler blower access panel.
 - After installation, make sure that the low-voltage and high-voltage wiring are kept separate.

4.3 Grounding



Danger: Electric shock

- The device must be permanently grounded. Otherwise, it will cause electric shock, personal injury or death.

- When installed according to existing electrical codes, grounding can be through wires or metal conductors.
- Grounding can also be achieved by connecting the grounding wire to the ground lug (ground lug) on the machine.
- When multiple power supply circuits are used, each circuit needs to be grounded plate separately.
- The grounding plate is located at the upper right of the cabinet.

4.4 Electrical Data

Table 4.1 Electrical data

Model	Voltage	Hertz	HP	Fan speed	Circuit AMPS	Maximum circuit protector
24K	208/230	60	1/3	5	1.1	5 (A)
36K	208/230	60	1/2	5	2.0	5 (A)
48K	208/230	60	3/4	5	3.5	5 (A)
60K	208/230	60	3/4	5	4.3	5 (A)

Table 4.2 Electrical data

Model	Voltage	Hertz	HP	Fan speed	Circuit AMPS	Maximum circuit protector
18K	208/230	60	1/3	5	0.8	5 (A)
24K	208/230	60	1/3	5	1.1	5 (A)
30K	208/230	60	1/2	5	1.3	5 (A)
36K	208/230	60	1/2	5	2.0	5 (A)
42K	208/230	60	3/4	5	2.2	5 (A)
48K	208/230	60	3/4	5	3.5	5 (A)
60K	208/230	60	3/4	5	4.3	5 (A)

4.5 MCA/MOP data of electric heat kit

Table 4.3 Applicable heat kits for AHU multi position installation

Heat kit model	AHU model	(kW) electric heat	MIN. Circuit Ampacity		MAX. Fuse or Breaker (HACR) Ampacity		Fan speed				
			230 VAC	208 VAC	230 VAC	208 VAC	1	2	3	4	5
21-4223-01	18K	5	22.68	19.66	25	25	●	●	●	●	●
21-4223-02		7.5	34.04	29.50	40	35	×	×	●	●	●
21-4223-01	24K	5	22.68	19.66	25	25	●	●	●	●	●
21-4223-02		7.5	34.04	29.50	40	35	×	×	●	●	●
21-4223-03		10	45.37	39.32	55	45	×	×	●	●	●
21-4223-01	30K	5	22.68	19.66	25	25	●	●	●	●	●
21-4223-02		7.5	34.04	29.50	40	35	×	●	●	●	●
21-4223-03		10	45.37	39.32	55	45	×	×	●	●	●
21-4223-01	36K	5	22.68	19.66	30	30	●	●	●	●	●
21-4223-02		7.5	34.04	29.50	40	35	×	●	●	●	●
21-4223-03		10	45.37	39.32	60	60	×	×	●	●	●
21-4223-04		15	34.04/34.04	29.50/29.50	40/40	35/35	×	×	●	●	●
21-4223-01	42K	5	22.68	19.66	25	25	●	●	●	●	●
21-4223-02		7.5	34.04	29.50	40	35	●	●	●	●	●
21-4223-03		10	45.37	39.32	55	45	×	●	●	●	●
21-4223-04		15	34.04/34.04	29.50/29.50	40/40	35/35	×	×	●	●	●
21-4223-01	48K	5	22.68	19.66	25	25	●	●	●	●	●
21-4223-02		7.5	34.04	29.50	40	35	●	●	●	●	●
21-4223-03		10	45.37	39.32	55	45	×	●	●	●	●
21-4223-04		15	34.04/34.04	29.50/29.50	40/40	35/35	×	×	●	●	●
21-4223-05		20	45.37/45.37	39.32/39.32	55/55	45/45	×	×	×	●	●
21-4223-01	60K	5	22.68	19.66	25	25	×	×	●	●	●
21-4223-02		7.5	34.04	29.50	40	35	×	×	●	●	●
21-4223-03		10	45.37	39.32	55	45	×	×	●	●	●
21-4223-04		15	34.04/34.04	29.50/29.50	40/40	35/35	×	×	●	●	●
21-4223-05		20	45.37/45.37	39.32/39.32	55/55	45/45	×	×	×	●	●

- Heat kit applicable for AHU 4-way position installation.
- Ampacities for MCA and Fuse/breaker including the blower motor
- The heat pump system needs specific airflow. Each ton of cooling requires 350 to 450 cubic feet (CFM) of air per minute, or nominally 400 CFM.

Table 4.4 Heater Kit Accessories

Model	Description	18	24	30	36	42	48	60
21-4223-01	5 kW heating kit, single-pole circuit breaker	●	●	●	●	●	●	●
21-4223-02	7.5 kW heating kit, single-pole circuit breaker	●	●	●	●	●	●	●
21-4223-03	10 kW heating kit, single/double pole circuit breaker	×	●	●	●	●	●	●
21-4223-04	15kW heating kit, double pole circuit breaker	×	×	×	●	●	●	●
21-4223-05	20 kW heating kit, double pole circuit breaker	×	×	×	×	×	●	●

● indicates availability, and × indicates unavailability

Warning:



- The electric heating must be installed by qualified personnel. Refer to current regulations and laws for installation location.
- This appliance is not intended for use by persons (including children) with reduced physical, sensory or mental capabilities, or lack of experience and knowledge, unless they have been given supervision or instruction concerning use of the appliance by a person responsible for their safety. Children should be supervised to ensure that they do not play with the appliance.
- The appliance shall be installed in accordance with national wiring regulations.

5. Airflow performance

The air flow data is based on the cooling performance of coil and without filter screen. Performance table, select the appropriate product.

External static pressure ESP should be kept within the minimum and maximum limits shown in the following table to ensure the normal operation of cooling, heating and electric heating.

Table 5.1 Air flow performance

Model size of air processor	Motor speed		SCFM									
			External Static Pressure-Inch Water Column [kPa]									
			0[0]	0.1[.02]	0.2[.05]	0.3[.07]	0.4[.10]	0.5[.12]	0.6[.15]	0.7[.17]	0.8[.20]	
24K	Gear (5)	SCFM	1193	1130	1072	1002	931	853	781	722	653	
		Watts	139	145	154	161	171	177	187	197	202	
	Gear (4)- default high wind	SCFM	1128	1060	998	920	850	766	693	622	573	
		Watts	117	122	132	139	148	155	164	170	180	
	Gear (3)	SCFM	1028	971	905	827	753	664	598	535	493	
		Watts	95	102	111	118	127	133	141	148	156	
	Gear (2)- Default low wind	SCFM	907	826	752	657	574	498	445	-	-	
		Watts	66	71	79	85	93	100	107	-	-	
	Gear (1)	SCFM	697	589	484	382	320	-	-	-	-	
		Watts	34	37	45	49	56	-	-	-	-	
	36K	Gear (5)	SCFM	1491	1438	1390	1337	1290	1245	1187	1112	1053
			Watts	250	256	266	273	284	297	309	317	327
Gear (4)- default high wind		SCFM	1357	1309	1250	1206	1158	1093	1018	960	890	
		Watts	193	205	209	220	231	239	251	262	268	
Gear (3)		SCFM	1238	1184	1115	1069	1006	931	870	792	728	
		Watts	147	157	163	174	181	193	204	210	220	
Gear (2)- Default low wind		SCFM	1116	1055	987	932	850	789	720	639	562	
		Watts	113	127	128	139	146	157	167	174	183	
Gear (1)		SCFM	1061	937	851	762	692	599	536	472	432	
		Watts	100	94	96	104	113	119	128	134	142	
48K		Gear (5)	SCFM	2081	2047	2011	1974	1933	1884	1823	1768	1718
			Watts	520	532	543	554	566	570	567	563	560
	Gear (4)	SCFM	1914	1874	1830	1787	1744	1703	1660	1609	1571	
		Watts	407	418	432	439	449	460	473	479	483	
	Gear (3)- default high wind	SCFM	1766	1720	1675	1636	1588	1540	1486	1441	1392	
		Watts	317	327	337	349	358	367	378	386	403	
	Gear (2)	SCFM	1559	1514	1462	1408	1362	1318	1265	1203	1137	
		Watts	214	235	246	252	263	273	284	296	308	
	Gear (1)- default low wind	SCFM	1370	1319	1271	1215	1164	1102	1035	950	882	
		Watts	159	169	179	185	195	207	219	228	239	
	60K	Gear (5)	SCFM	2081	2047	2011	1974	1933	1884	1823	1768	1718
			Watts	520	532	543	554	566	570	567	563	560
Gear (4)- default high wind		SCFM	1914	1874	1830	1787	1744	1703	1660	1609	1571	
		Watts	407	418	432	439	449	460	473	479	483	
Gear (3)		SCFM	1766	1720	1675	1636	1588	1540	1486	1441	1392	
		Watts	317	327	337	349	358	367	378	386	403	
Gear (2)- Default low wind		SCFM	1559	1514	1462	1408	1362	1318	1265	1203	1137	
		Watts	214	235	246	252	263	273	284	296	308	
Gear (1)		SCFM	1370	1319	1271	1215	1164	1102	1035	950	882	
		Watts	159	169	179	185	195	207	219	228	239	

Table 5.2 Air Flow Performance

Model size of air processor	Motor speed		SCFM									
			External Static Pressure-Inch Water Column [kPa]									
			0[0]	0.1[.02]	0.2[.05]	0.3[.07]	0.4[.10]	0.5[.12]	0.6[.15]	0.7[.17]	0.8[.20]	
18K	Gear (5)	SCFM	1193	1130	1072	1002	931	853	781	722	653	
		Watts	139	145	154	161	171	177	187	197	202	
	Gear (4)- default high wind	SCFM	1128	1060	998	920	850	766	693	622	573	
		Watts	117	122	132	139	148	155	164	170	180	
	Gear (3)	SCFM	1028	971	905	827	753	664	598	535	493	
		Watts	95	102	111	118	127	133	141	148	156	
	Gear (2)- Default low wind	SCFM	907	826	752	657	574	498	445	-	-	
		Watts	66	71	79	85	93	100	107	-	-	
	Gear (1)	SCFM	697	589	484	382	320	-	-	-	-	
		Watts	34	37	45	49	56	-	-	-	-	
	24K	Gear (5)	SCFM	1193	1130	1072	1002	931	853	781	722	653
			Watts	139	145	154	161	171	177	187	197	202
Gear (4)- default high wind		SCFM	1128	1060	998	920	850	766	693	622	573	
		Watts	117	122	132	139	148	155	164	170	180	
Gear (3)		SCFM	1028	971	905	827	753	664	598	535	493	
		Watts	95	102	111	118	127	133	141	148	156	
Gear (2)- Default low wind		SCFM	907	826	752	657	574	498	445	-	-	
		Watts	66	71	79	85	93	100	107	-	-	
Gear (1)		SCFM	697	589	484	382	320	-	-	-	-	
		Watts	34	37	45	49	56	-	-	-	-	
30K		Gear (5)	SCFM	1491	1438	1390	1337	1290	1245	1187	1112	1053
			Watts	250	256	266	273	284	297	309	317	327
	Gear (4)- default high wind	SCFM	1357	1309	1250	1206	1158	1093	1018	960	890	
		Watts	193	205	209	220	231	239	251	262	268	
	Gear (3)	SCFM	1238	1184	1115	1069	1006	931	870	792	728	
		Watts	147	157	163	174	181	193	204	210	220	
	Gear (2)- Default low wind	SCFM	1116	1055	987	932	850	789	720	639	562	
		Watts	113	127	128	139	146	157	167	174	183	
	Gear (1)	SCFM	1061	937	851	762	692	599	536	472	432	
		Watts	100	94	96	104	113	119	128	134	142	
	36K	Gear (5)	SCFM	1491	1438	1390	1337	1290	1245	1187	1112	1053
			Watts	250	256	266	273	284	297	309	317	327
Gear (4)- default high wind		SCFM	1357	1309	1250	1206	1158	1093	1018	960	890	
		Watts	193	205	209	220	231	239	251	262	268	
Gear (3)		SCFM	1238	1184	1115	1069	1006	931	870	792	728	
		Watts	147	157	163	174	181	193	204	210	220	
Gear (2)- Default low wind		SCFM	1116	1055	987	932	850	789	720	639	562	
		Watts	113	127	128	139	146	157	167	174	183	
Gear (1)		SCFM	1061	937	851	762	692	599	536	472	432	
		Watts	100	94	96	104	113	119	128	134	142	

42K	Gear (5)	SCFM	2081	2047	2011	1974	1933	1884	1823	1768	1718
		Watts	520	532	543	554	566	570	567	563	560
	Gear (4)	SCFM	1914	1874	1830	1787	1744	1703	1660	1609	1571
		Watts	407	418	432	439	449	460	473	479	483
	Gear (3)- default high wind	SCFM	1766	1720	1675	1636	1588	1540	1486	1441	1392
		Watts	317	327	337	349	358	367	378	386	403
	Gear (2)	SCFM	1559	1514	1462	1408	1362	1318	1265	1203	1137
		Watts	214	235	246	252	263	273	284	296	308
Gear (1)- default low wind	SCFM	1370	1319	1271	1215	1164	1102	1035	950	882	
	Watts	159	169	179	185	195	207	219	228	239	
48K	Gear (5)	SCFM	2081	2047	2011	1974	1933	1884	1823	1768	1718
		Watts	520	532	543	554	566	570	567	563	560
	Gear (4)	SCFM	1914	1874	1830	1787	1744	1703	1660	1609	1571
		Watts	407	418	432	439	449	460	473	479	483
	Gear (3)- default high wind	SCFM	1766	1720	1675	1636	1588	1540	1486	1441	1392
		Watts	317	327	337	349	358	367	378	386	403
	Gear (2)	SCFM	1559	1514	1462	1408	1362	1318	1265	1203	1137
		Watts	214	235	246	252	263	273	284	296	308
Gear (1)- default low wind	SCFM	1370	1319	1271	1215	1164	1102	1035	950	882	
	Watts	159	169	179	185	195	207	219	228	239	
60K	Gear (5)	SCFM	2081	2047	2011	1974	1933	1884	1823	1768	1718
		Watts	520	532	543	554	566	570	567	563	560
	Gear (4)- default high wind	SCFM	1914	1874	1830	1787	1744	1703	1660	1609	1571
		Watts	407	418	432	439	449	460	473	479	483
	Gear (3)	SCFM	1766	1720	1675	1636	1588	1540	1486	1441	1392
		Watts	317	327	337	349	358	367	378	386	403
	Gear (2)- Default low wind	SCFM	1559	1514	1462	1408	1362	1318	1265	1203	1137
		Watts	214	235	246	252	263	273	284	296	308
Gear (1)	SCFM	1370	1319	1271	1215	1164	1102	1035	950	882	
	Watts	159	169	179	185	195	207	219	228	239	

 The bold area indicates the airflow beyond the required range of 300-450cfm/ton.

Note:

1. The advanced airflow must be used as the rated airflow for the full-load operation of the machine.
2. The rated airflow of a system without an electric heater kit requires 300 to 450 cubic feet of air per minute (CFM).
3. The rated airflow of a system with an electric heater kit requires 350 to 450 cubic feet of air per minute (CFM).
4. The air distribution system has the greatest influence on air flow. Therefore, the contractor should only use the procedures recognized by the industry.
5. The design and construction of air duct should be done carefully. Poor design or process will lead to a significant decline in system performance.
6. The air supply duct should be set along the periphery of the air-conditioned space with appropriate size. Improper location or insufficient airflow may lead to insufficient ventilation or noise in the pipeline system.
7. The installer should balance the air distribution system to ensure that all rooms in the room have proper quiet airflow. The speedometer or airflow hood can be used to balance and verify the branch pipe and system airflow (CFM).

5.1 Indoor Fan Function

System Operation Function

Two-stage fan control

This model can be matched with a thermostat that supports two-stage fan control. When Y2 has a signal, the blower will run in high speed. When there is no signal in Y2 and there is a signal in Y1, the blower runs in low speed. When only G has a signal, the blower runs in low speed. When there is a signal in W1/W2, the blower runs in high speed.

This product supports five fan speeds. Please refer to the wiring diagram for wiring instructions.

If there is no thermostat supporting two-stage fan control, you can use one-stage fan control thermostat. Please refer to the wiring diagram for wiring instructions. If Y1 and Y2 are short-circuited, the blower only runs in high speed.

Anti-cooling fan delay

This function is realized by the T2 sensor of the internal unit, which prevents the fan from being turned on before the indoor coil reaches a certain temperature. This function can prevent the machine from blowing cold air during heating.

1. When the dial code SW3-1 is set to "OFF" and the machine is in heating mode. The delay function of cold air blower will take effect according to the following entry conditions (all conditions must be met):
 - A, Indoor coil temperature (T2) < 82.4°F .
 - B. Electric heating off
2. If one of the following exit conditions is met, the machine will exit the anti-cold air function:
 - A. T2 > 89.6°F
 - B. Electric heating on
 - C. The system is not running in heating mode.
3. In the heating mode, if one of the exit conditions of cold wind prevention is met, the machine will operate according to the set windshield.

Heating fan delay

If the dial code SW3-1 is set to "ON" and the machine is in heating mode, the fan will run for 90 seconds.

Passive Dehumidification Function (Optional)

This model has dehumidification function, which can make the blower run at low speed by DH signal sent by thermostat. This function needs to be supported by connecting an appropriate DH line from the indoor unit to the thermostat (with constant humidity function).



If the DH line is not connected, the equipment will still work normally.

6. Piping System

On-site piping system must comply with National Fire Protection Association NFPA 90A, NFPA 90B and any applicable local ordinance(s).

Warning: Fire and carbon monoxide



- Under no circumstances should the return piping system be connected to any other heat-producing equipment, such as mantelpiece, stove, etc. Unauthorized use of such equipment may cause fire, carbon monoxide poisoning, explosion, personal injury or property damage.
-

The metal piping system operating in the air-conditioned space must be insulated and covered with a moisture-proof layer. If the construction and installation are carried out according to SMACNA glass fiber pipeline construction standard, the fiber pipeline system can be used. The piping system must meet the U/L standard 181 test of Class I air duct by National Fire Protection Association of America. Check the local regulations of piping system and insulation requirements.

- The pipeline system must be designed within the external static pressure range of the designed operation of the device. Adequate airflow in the system is very important. Ensure that the supply and return piping system, grid, special filter screen, accessories, etc. are included in the total resistance. Please refer to the airflow performance table in Section 5 of this manual.
 - Design the piping system according to "ACCA" manual "D" residential air conditioning design and equipment selection in winter and summer. The latest version can be obtained from "ACCA" American Air Conditioning Contractors Association, 1513 16th Street NW, Washington, DC, 20036. If the piping system contains flexible air pipes, make sure that the system takes into account the pressure drop information (straight line length plus all turns) shown in "ACCA" manual "D".
 - The air duct connector should be connected to the 3/4 "flange on the equipment. Install a flange around the air outlet.
-



If the duct connector has an elbow, its size should not be smaller than that of the flange on the outlet of the device.



The front flange on the return duct (if connected to the fan casing) must not be screwed into the area where the power cord is located. Drill bits or sharp screw tips can damage the insulation of the internal wires of the equipment.

- Use appropriate fasteners suitable for the type of pipe used, fix the outlet and return pipes to the flanges of the device, and connect the pipes to the device with adhesive tape as needed to prevent air leakage.

7. Refrigerant Pipe Connection

Before the refrigerant pipe connection is completed, keep the coil sealed. Please refer to the installation, operation and maintenance manual of the external machine for detailed information on pipe size, pipe installation and filling amount.

Drain the system before filling the refrigerant.

Care should be taken to connect the refrigerant pipe so that it will not obstruct the maintenance channel in front of the equipment.

During brazing, nitrogen should flow through the refrigerant pipe.

Use a brazing shield to protect the paint of the cabinet, and use a wet rag to protect the rubber gasket and the piston sealing ring of the pipeline from being damaged by the torch flame. During the brazing process, protect the temperature sensing bulb of TXV with wet cloth or approved heating paste. See Figure 7.1.

After the refrigerant pipeline connection is completed, seal and fill the surrounding gaps with pressure-sensitive gaskets.

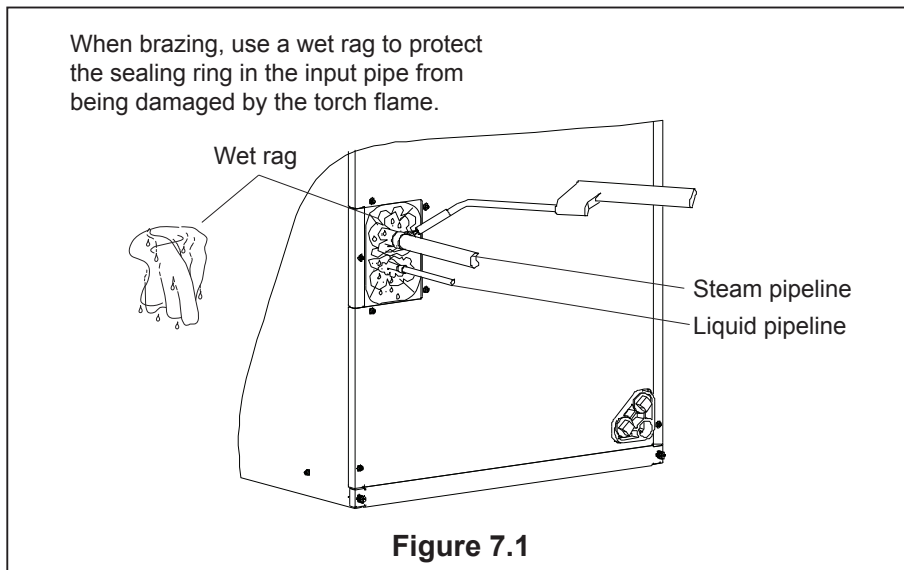

After brazing, make sure that there is no refrigerant leakage. After checking the vapor leakage, make sure that the pipeline is insulated, as shown in Figure 7.2.

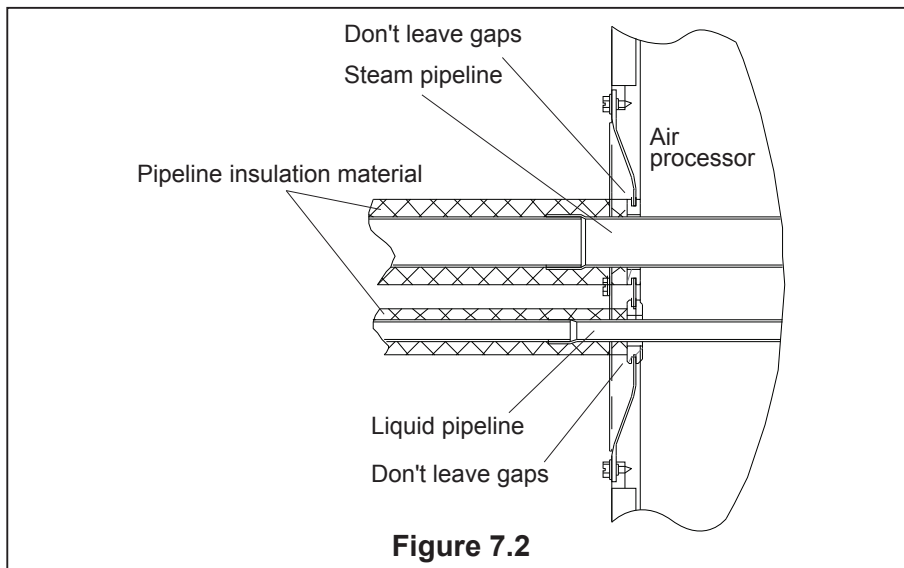

7.1 Condensate Drain Connection

For specific requirements, please consult local codes.

For the required condensate trap installation, please refer to Figure 7.3 and the following information.

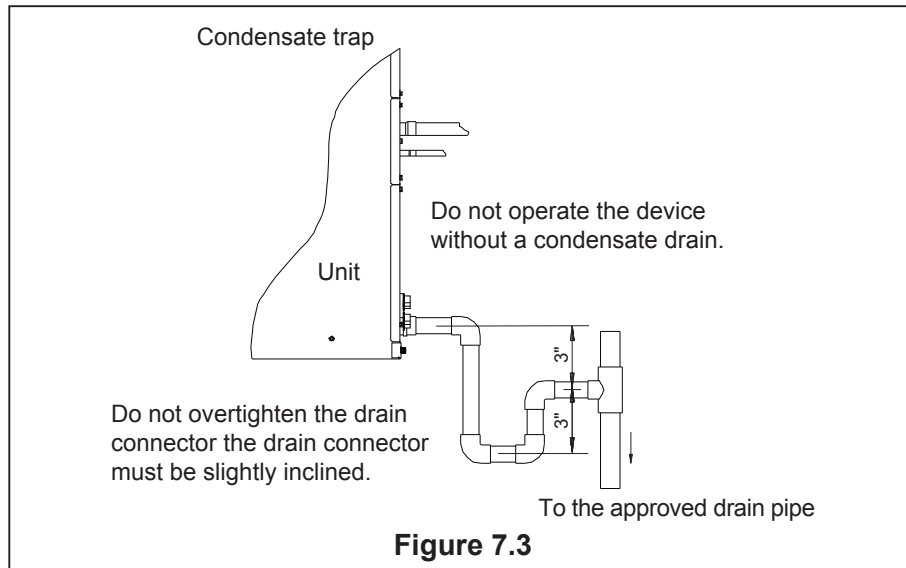

1. When connecting the drain connector to the drain pan, use a thin layer of PTFE paste, silicone or PTEF, and tighten it by hand.
2. When connecting the drain connector to the drain pan, don't over tighten it. Tight fittings will crack the pipe connection on the drain pan.

- Make sure that the drainage pipe will not block the inlet in front of the device. The minimum clearance required for removal and maintenance of filter screen, coil or fan is 24 inches.
- Make sure that the machine is placed horizontally or slightly inclined to the main drain outlet, so that water can be completely drained from the machine.
- Do not reduce the drain pipe size to less than the connection size provided on the condensate drain pan.
- All horizontal drainage pipes must be inclined downward at a slope of at least 1/8 inch per foot to ensure proper drainage.
- Do not connect the condensate drain line to the closed or open sewage pipe. Drain the condensate to an open drainage pipe or to a safe outdoor area.
- Where necessary, the drainage pipeline should be insulated to prevent damage caused by condensation water formed on the outer surface of the pipeline.
- If necessary, be prepared to disconnect and clean the main drainage pipe. Install a 3-inch elbow on the main drainage pipe as close as possible to the unit. Make sure that the top of the elbow is lower than the joint of the drain pan to allow the drain pan to drain completely (see Figure 7.3).
- Auxiliary drainage pipes should be extended to places where condensate can be easily seen. If the condensed water starts to flow out from the auxiliary drain pipe, the homeowner should pay attention to the possible problems.
- Plug the unused drain connector with the plug in the parts package provided with the equipment. Use a thin layer of Teflon paste, silicone or Teflon tape to form a waterproof seal.
- After installation, test the condensate drain pan and drain pipe. Pour water into the drain pan, enough to fill the drain traps and pipes. Check to ensure that the drain pan completely drains water, no leakage is found in the drain pipe fittings, and water is discharged from the main drain pipe terminal.

8. Air Filter (Not Factory Installed)

The filter is not included in the device and must be provided on site.

The size of external filters or other filtering devices must meet the maximum flow rate of 300ft/min, or meet the recommended value of filter type.

The application and placement of filter is very important for airflow, which may affect the performance of heating and cooling system. Reduced airflow will shorten the life of the main components of the system, such as motors, components, thermal relays, evaporator coils or compressors. Therefore, we recommend that the return air duct system has only one filter position. For systems without return air filter grids, multiple filter grids can be installed at each return air opening.

If a high-efficiency filter screen or electronic air filtration system is used, it is very important that the air flow rate is not reduced. If the air flow decreases, the overall performance and efficiency of the device will decrease. It is strongly recommended to contact professional installation technicians to ensure the correct installation of such filtration systems.



Do not double filter the return air system. Do not filter the air supply duct system. This will change the performance of the device and reduce the airflow.



Warning: Fire risk

- Do not operate the system without a filter. Part of the dust suspended in the air may temporarily stay on the duct and the air outlet of the room. Any circulating dust particles may be heated and burnt due to contact with AHU elements. This residue will stain the ceiling, walls, curtains, carpets and other items in the house. When some types of candles, oil lamps or igniters burn, soot may be generated in the filter.
-

9. Installation Size of Filter Screen

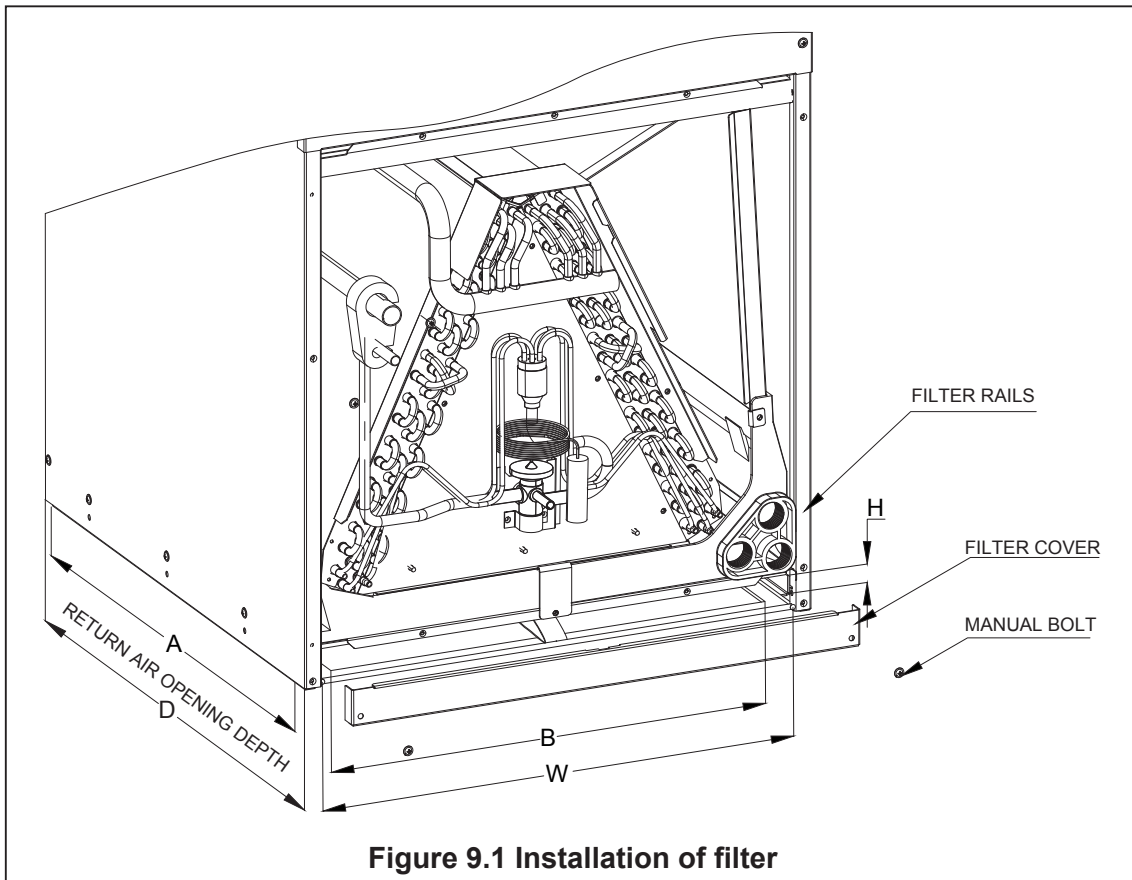

The filter is included in the device and must be provided on site.

Table 9.1 Size number

Model	Filter size inches [mm]	"W" Inch [mm]	"D" Inch [mm]	"H" Inch [mm]	Return Width "A" inch [mm]	Return Length "B" inch [mm]
18K/24K/30K/36K/42K	18.1×21.4[460×544]	18.3 [466]	21.6 [548]	1 [25.4]	20.8 [528]	16.3 [414]
48K/60K	20.5×23.8[521×605]	20.7 [526]	23.9 [608]	1 [25.4]	23 [584]	18.8 [478]

Removal/Installation of Air Filter

- Manually remove the bolts and remove the filter cover, as shown in Figure 9.1.
- Hold the edge of the strainer and pull it out.
- Install a new filter so that the arrow on the filter screen is consistent with the airflow direction.
- If a reusable filter is used, please clean it according to the manufacturer's specifications before re-installing it.

10. Maintenance



In order to keep high performance and minimize possible equipment failures, the equipment must be regularly maintained.

10.1 Cleaning Precautions



Warning:

- Any equipment maintenance can only be carried out by qualified maintenance personnel.
-



Warning: Before cleaning and maintenance

- Before cleaning or maintenance, be sure to turn off the equipment and disconnect its power supply.
-



Be careful:

- When removing the filter, do not touch the metal parts in the device. Sharp metal edges can cut you.
-



Note:

- Do not use chemicals or chemically treated cloth to clean the equipment.
 - Do not use benzene, paint thinner, polishing powder or other solvents to clean this machine.
 - Do not operate the system without a filter
-

10.2 Routine Maintenance

Your equipment must be inspected regularly by qualified service technicians. Your annual system check must include:

1. Check the filter every 90 days, or at any time as needed. If it is blocked or block, please clean or replace it immediately.
2. Inspection and/or cleaning of impeller housing and motor.
3. Check and clean indoor and outdoor coils as needed.
4. Check and/or clean indoor coil drain pan and drain pipe and auxiliary drain pan and pipe.
5. Check all wires and connections. Refer to the wiring diagram and make corrections as needed.

11. Wiring Diagram



Warning: Electric shock

- Before repairing or installing this device, please disconnect all power supplies. There may be multiple power sources. Otherwise, property damage, personal injury or death may result.
-



Danger: Electric shock

- The device must be properly grounded and protected by a circuit breaker or fuse.
-



Warning: Electric shock

- These devices must be wired and installed according to all national and local safety codes.
-

- To avoid electric shock, make sure:
 - 1) Equipment is properly grounded.
 - 2) The main power plug of the device has been connected to the ground wire (do not change it).
 - Do not tighten the power cord.
-



The dotted line in the following thermostat wiring diagram indicates optional wiring (wiring for passive dehumidification function and/or electric heating). For the wiring of the thermostat, please refer to the user manual of the thermostat.



Dh wiring is optional and requires a thermostat with a humidifier. Dh plays the role of passive dehumidification, and puts the indoor blower in the Low fan speed. If Dh wiring is missing, the system will run in the normal operation sequence.

Wiring for 3H and 2C thermostat

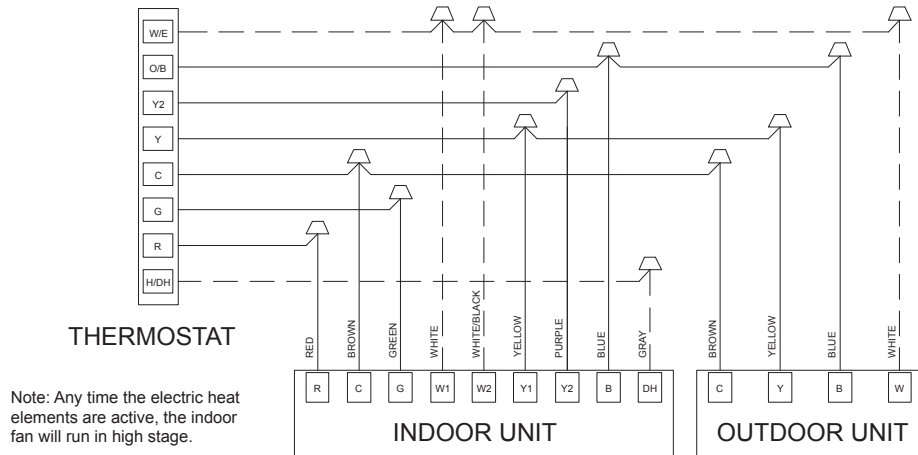

Figure 11.1 Control Wiring For HP Systems

Wiring for 4H and 2C thermostat

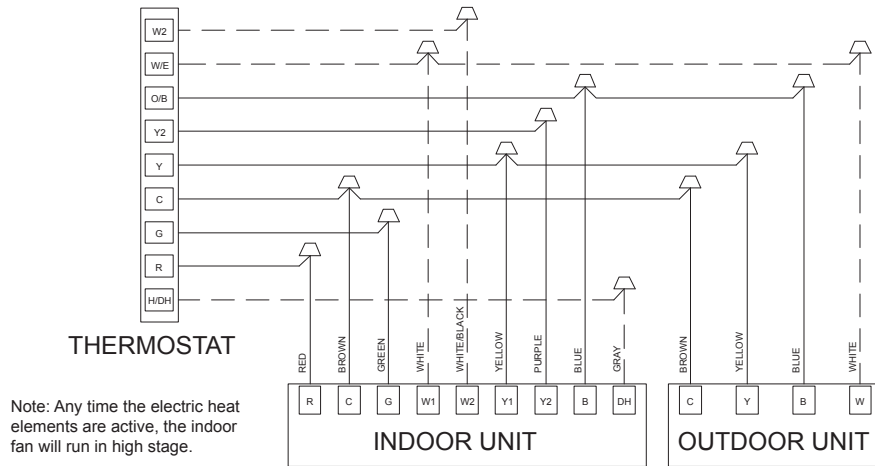

Figure 11.2 Control Wiring For HP Systems

Wiring for 3H and 1C thermostat

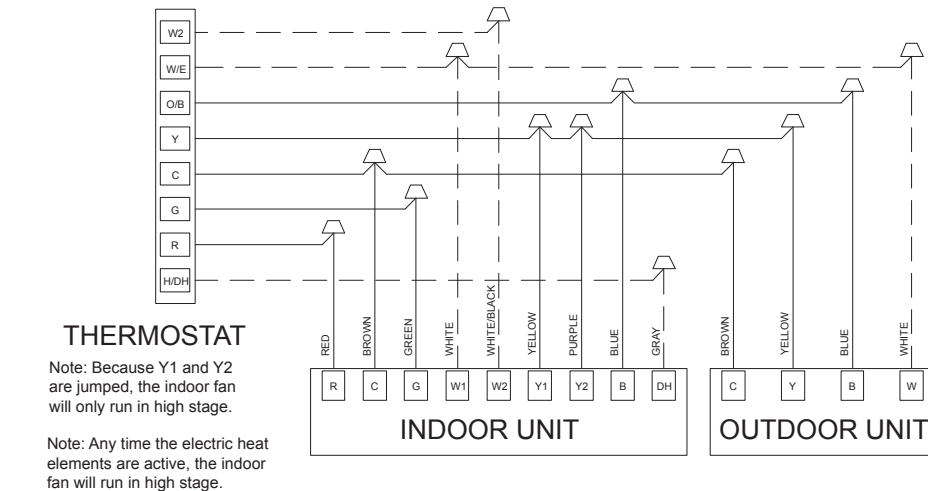

Figure 11.3 Control Wiring For HP Systems

Wiring for 2H and 2C thermostat

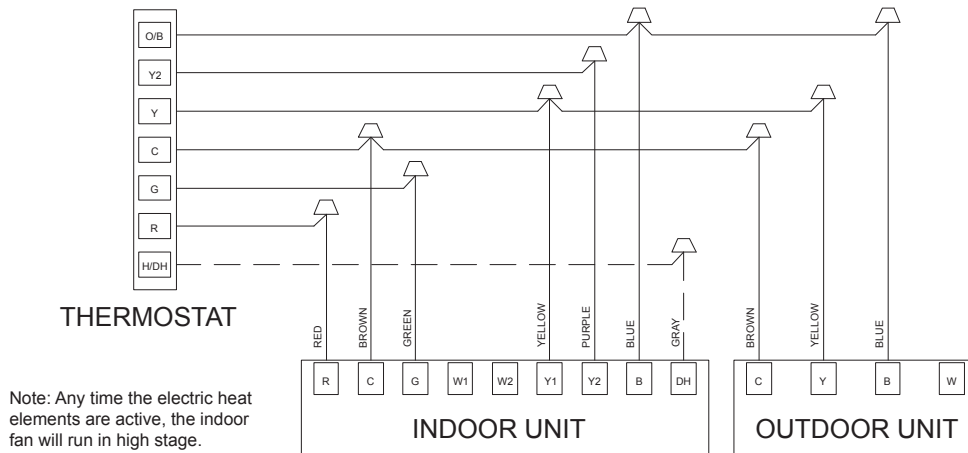

Figure 11.4 Control Wiring For HP Systems

Wiring for 1H and 1C thermostat

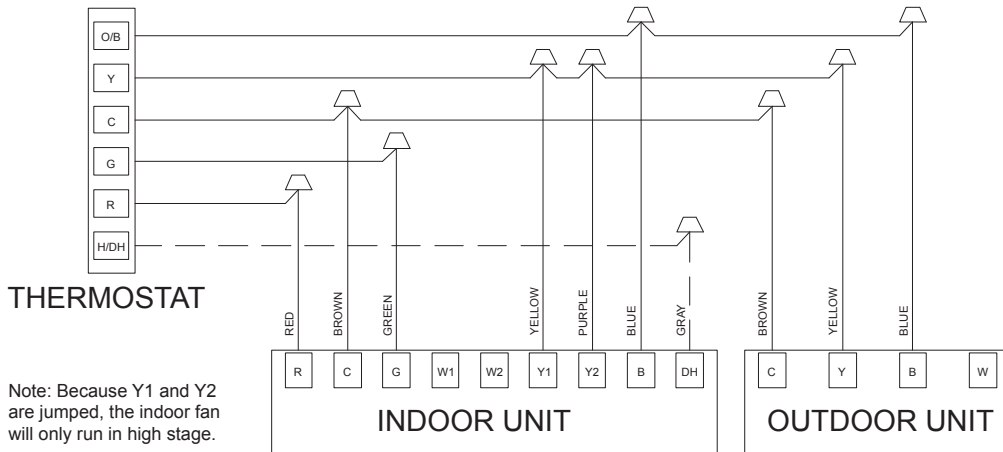

Figure 11.5 Control Wiring For HP Systems

Wiring for 2H and 1C thermostat

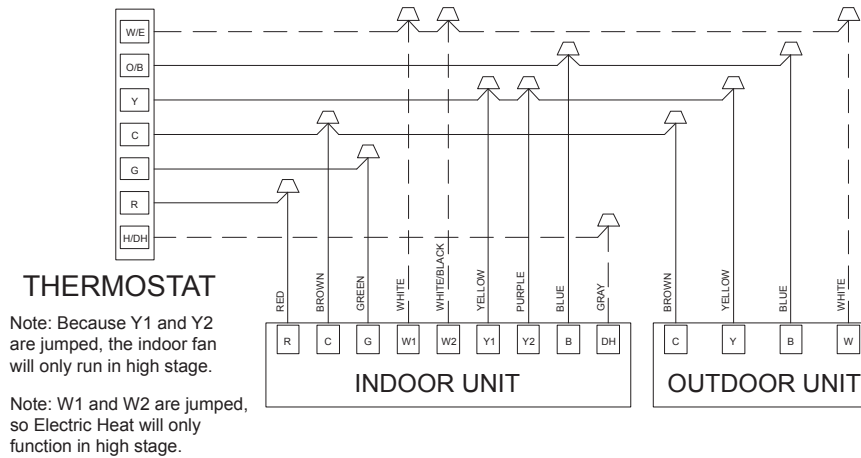

Figure 11.6 Control Wiring For HP Systems

Wiring for 3H and 2C thermostat

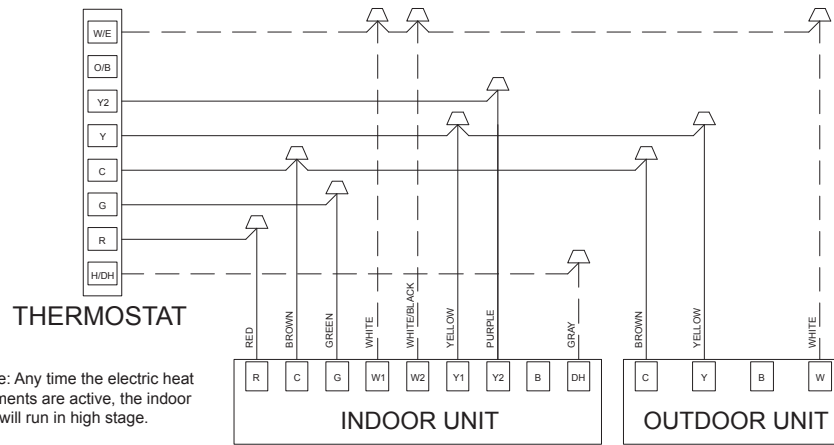

Figure 11.7 Control Wiring For AC Systems

Wiring for 4H and 2C thermostat

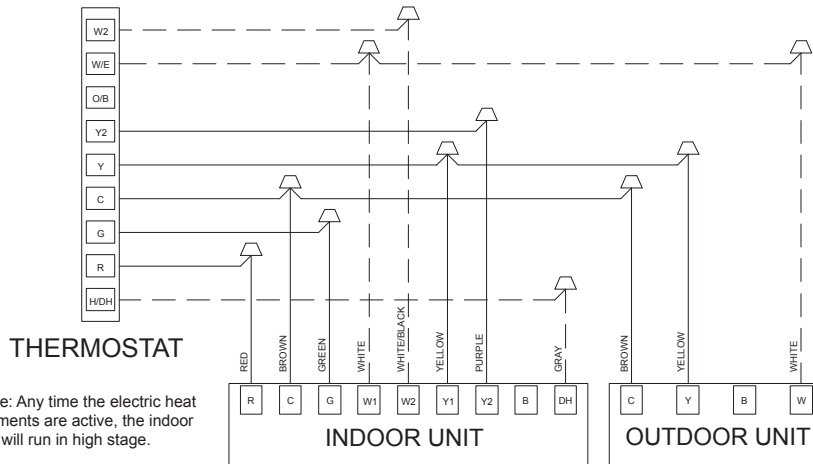

Figure 11.8 Control Wiring For AC Systems

Wiring for 3H and 1C thermostat

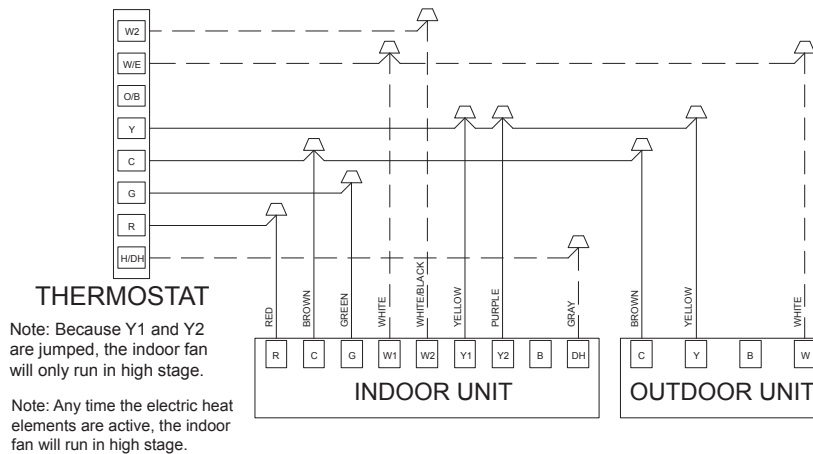

Figure 11.9 Control Wiring For AC Systems

Wiring for 2H and 2C thermostat

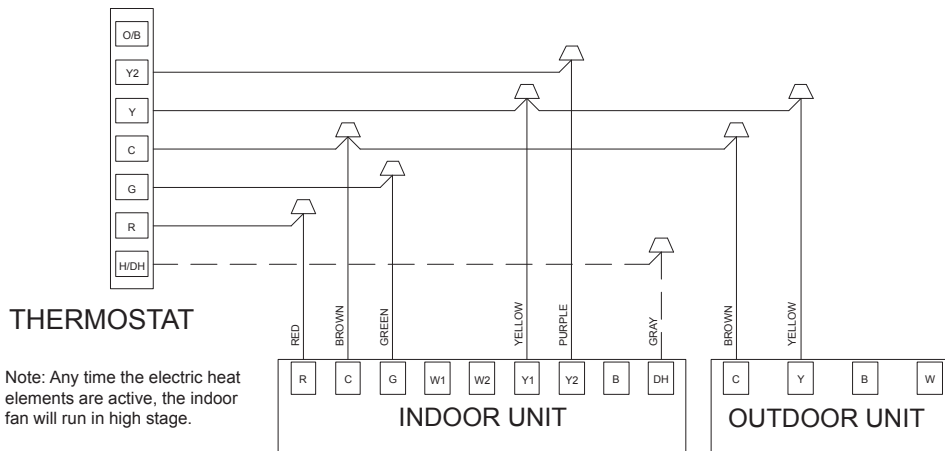

Figure 11.10 Control Wiring For AC Systems

Wiring for 1H and 1C thermostat

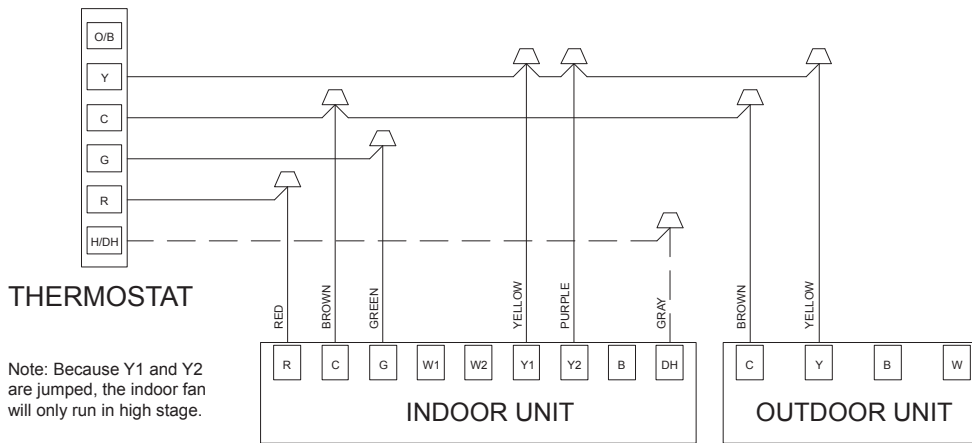

Figure 11.11 Control Wiring For AC Systems

Wiring for 2H and 1C thermostat

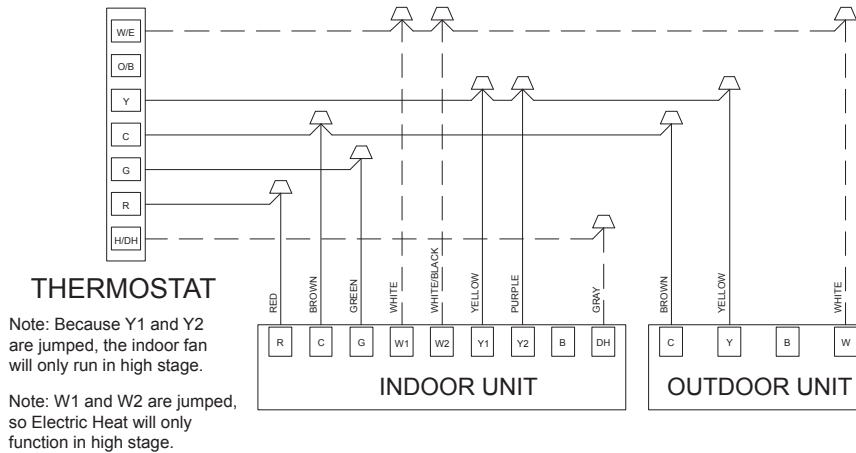
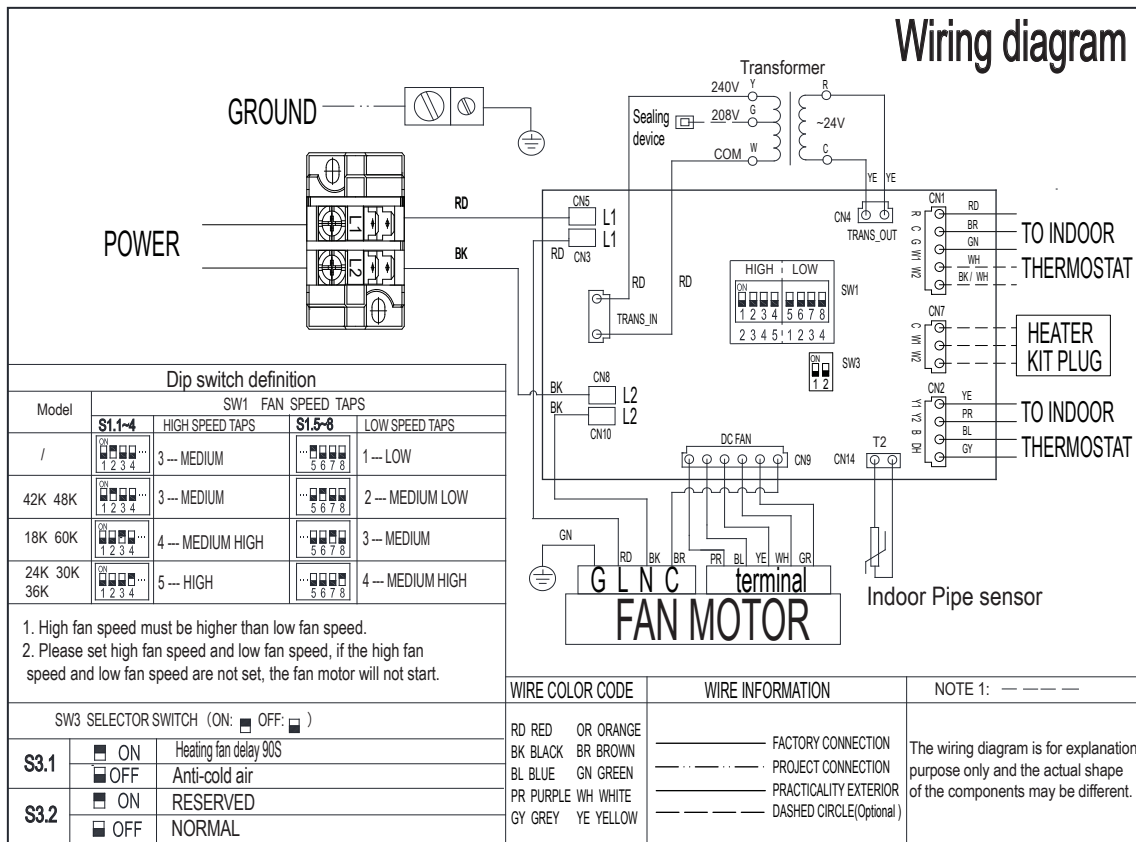

Figure 11.12 Control Wiring For AC Systems

Table 11.1 Wire gauge of high voltage system

Type (Btu/ hour)		18K	24K	30K	36K	42K	48K	60K	
Power	Stage	Single							
	Voltage/frequency	208/230VAC, 60 Hz							
Wire gauge	Indoor unit power cord	Line quantity	3	3	3	3	3	3	3
		Wire diameter (AWG)	16	16	16	16	16	16	16
	Outdoor unit power cord	Line quantity	3	3	3	3	3	3	3
		Wire diameter (AWG)	14	14	12	12	10	10	10



Applicable to 18K/24K/30K/36K/42K/48K/60K

NOTE: For reference only, the actual wiring diagram shall prevail

802035000084

Design, material, performance specifications and components
subject to change without notice.