

DIMENSIONAL DATA

AIR COOLED CONDENSING UNITS

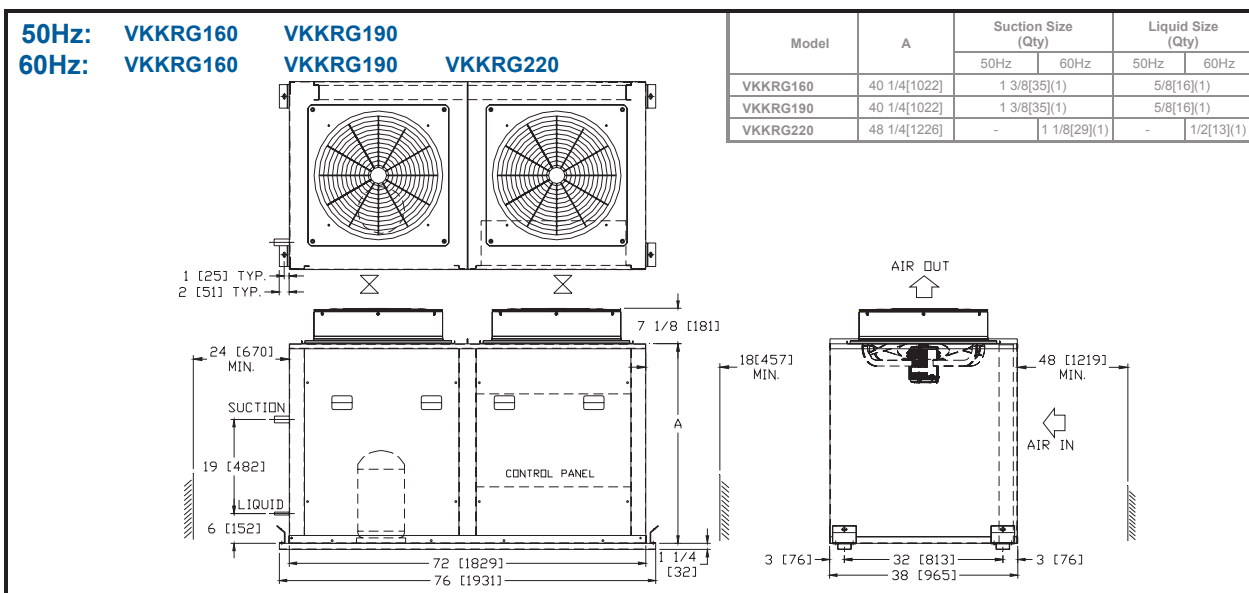
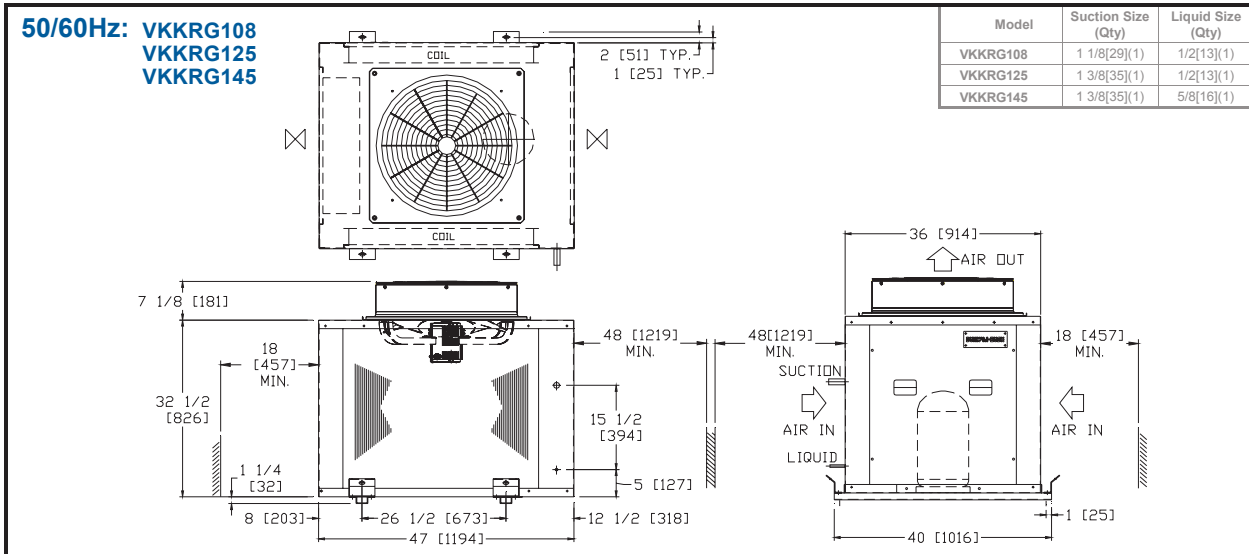
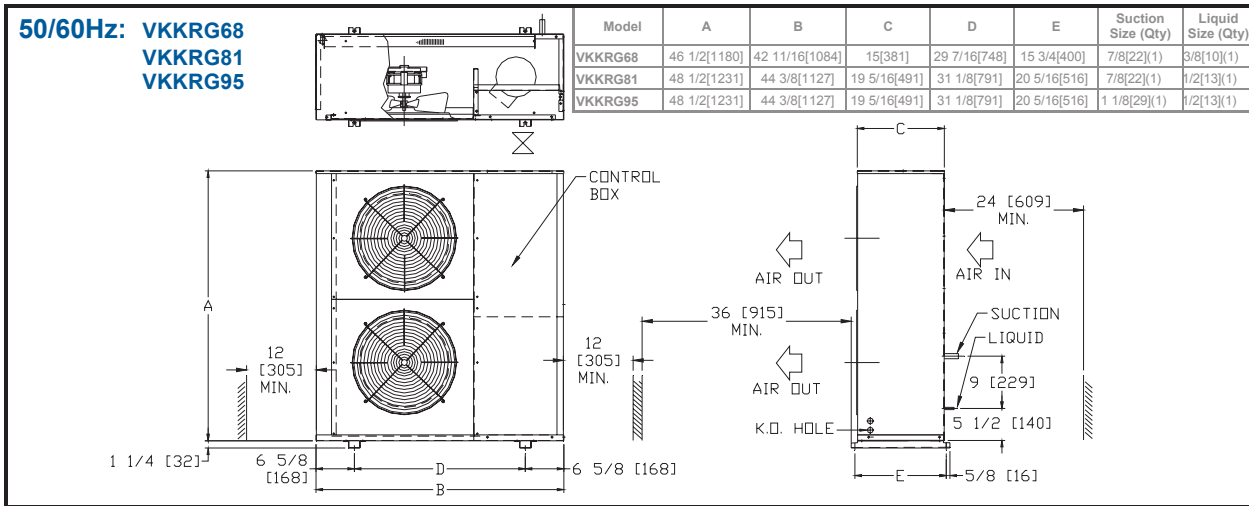

Note: All dimensions are in inches [mm].

DIMENSIONAL DATA

AIR COOLED CONDENSING UNITS

50Hz: VKKRG220 VKKRG250 VKKRG290
 60Hz: VKKRG250 VKKRG290

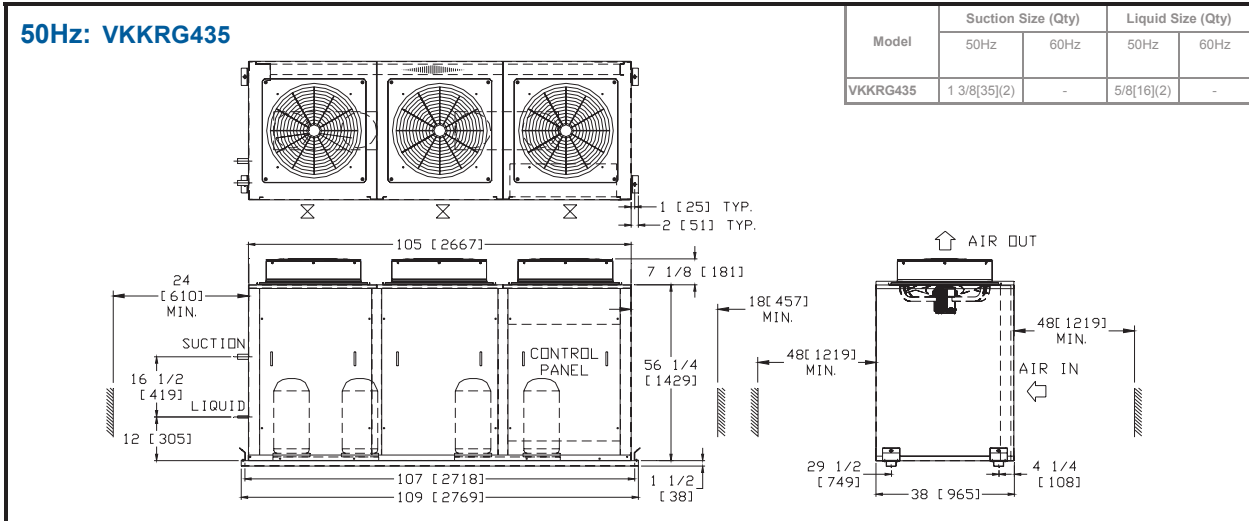
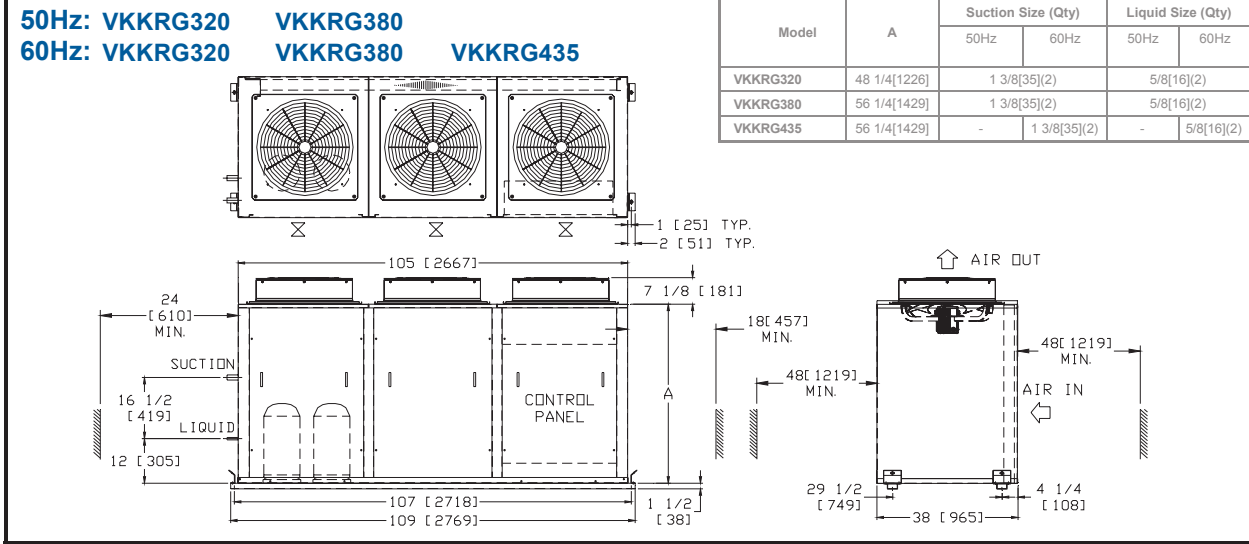
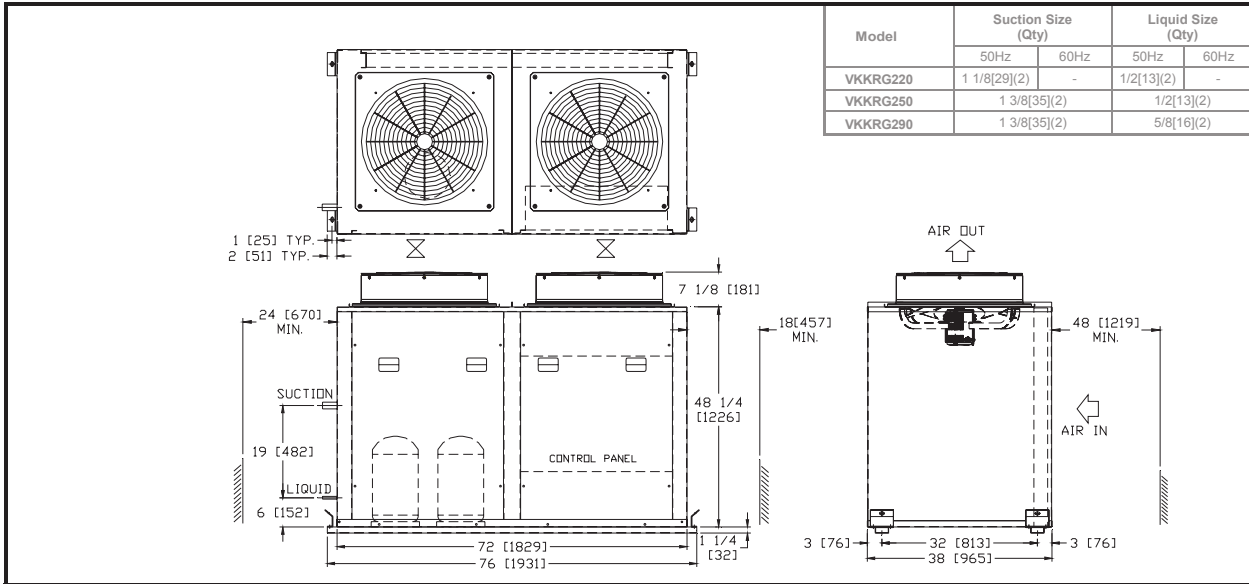

Note: All dimensions are in inches [mm].

DIMENSIONAL DATA

AIR COOLED CONDENSING UNITS

50/60Hz: VKKRG480 VKKRG510 VKKRG570

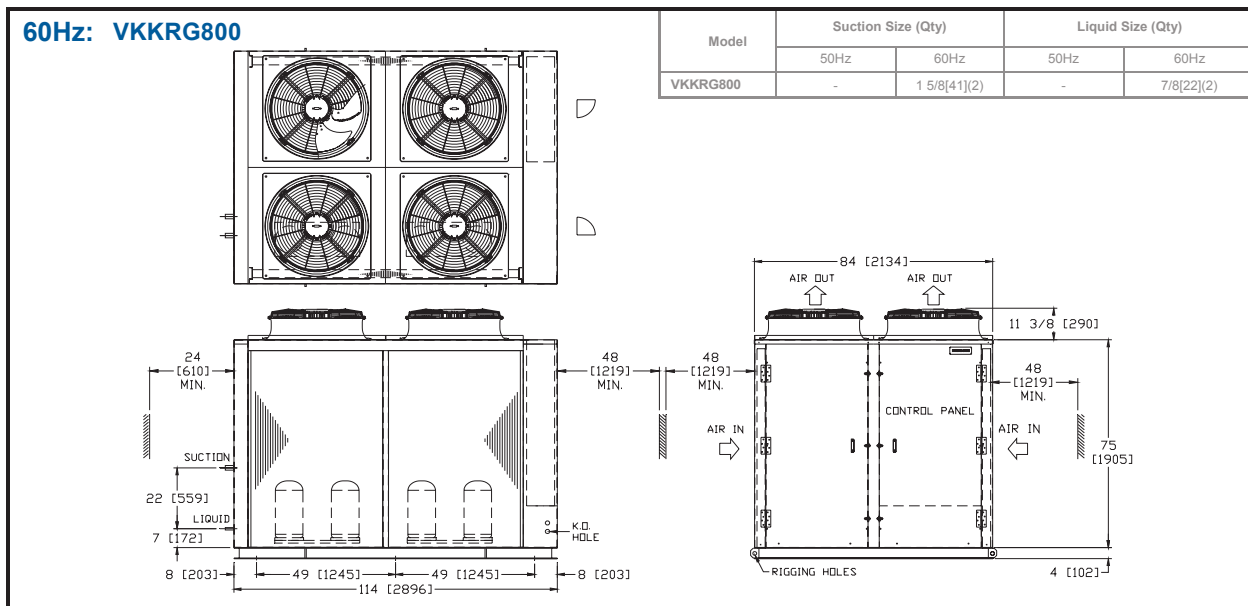
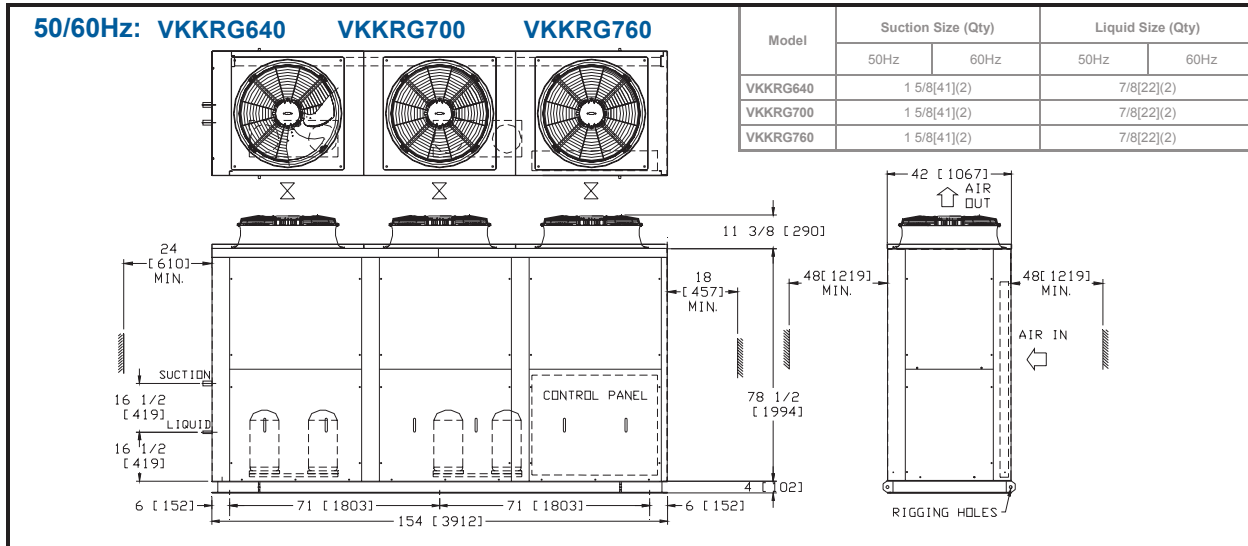
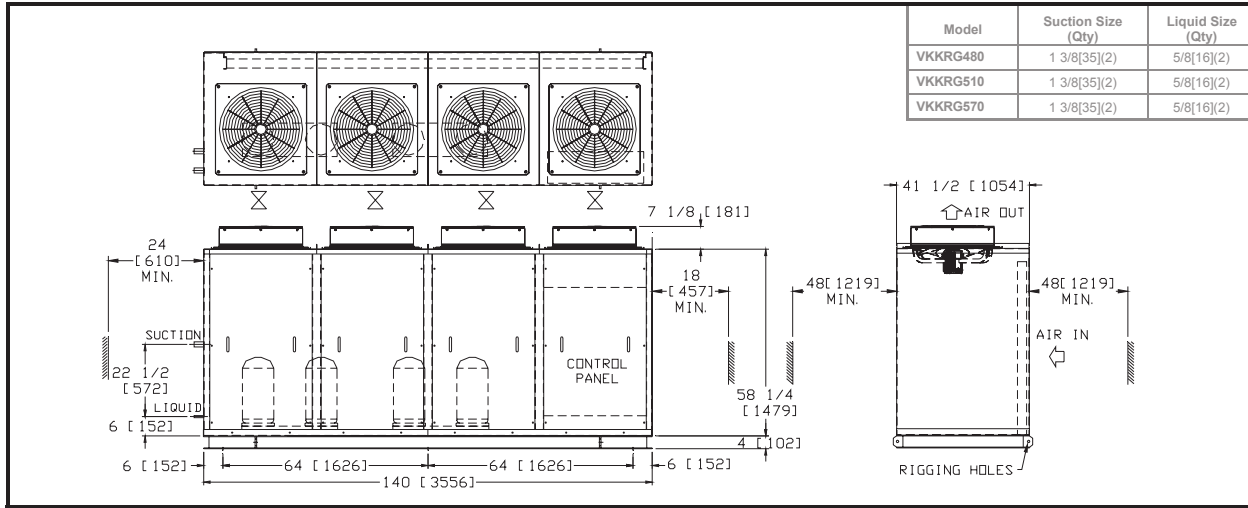

Note: All dimensions are in inches [mm].

DIMENSIONAL DATA

AIR COOLED CONDENSING UNITS

50Hz: VKKRG800 VKKRG890 VKKRG960
 60Hz: VKKRG890 VKKRG960

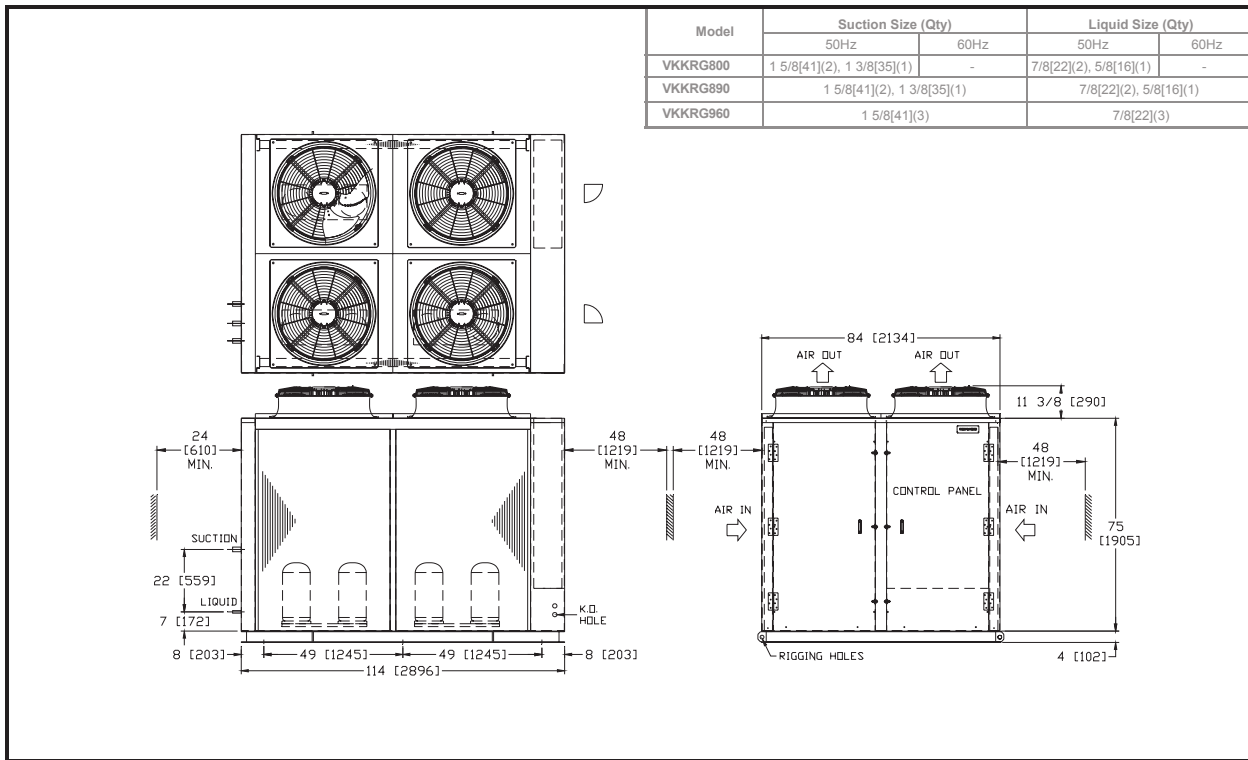

50Hz: VKKRG1020 VKKRG1140
 60Hz: VKKRG1020 VKKRG1140 VKKRG1340

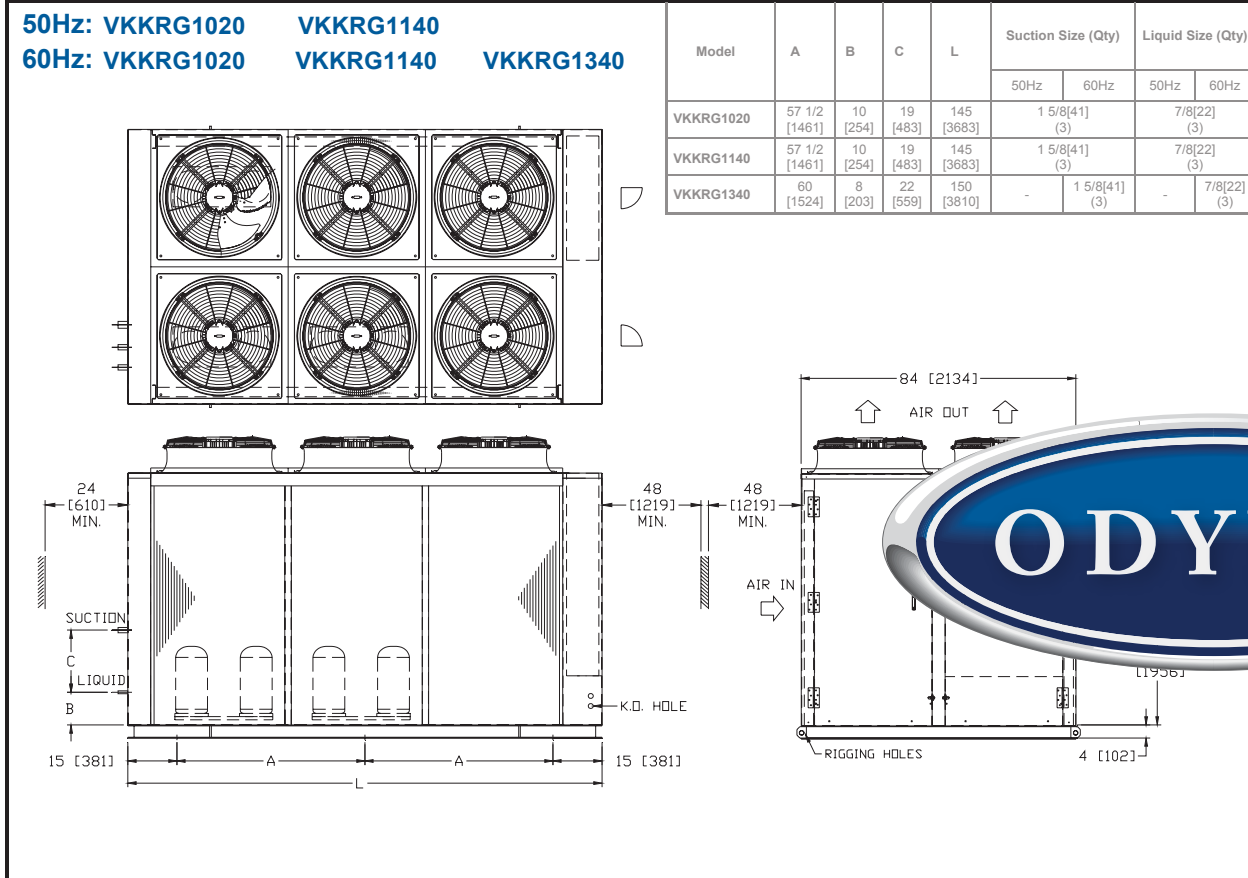

Note: All dimensions are in inches [mm].

DIMENSIONAL DATA

AIR COOLED CONDENSING UNITS

50Hz: VKKRG1340 VKKRG1520
 60Hz: VKKRG1520

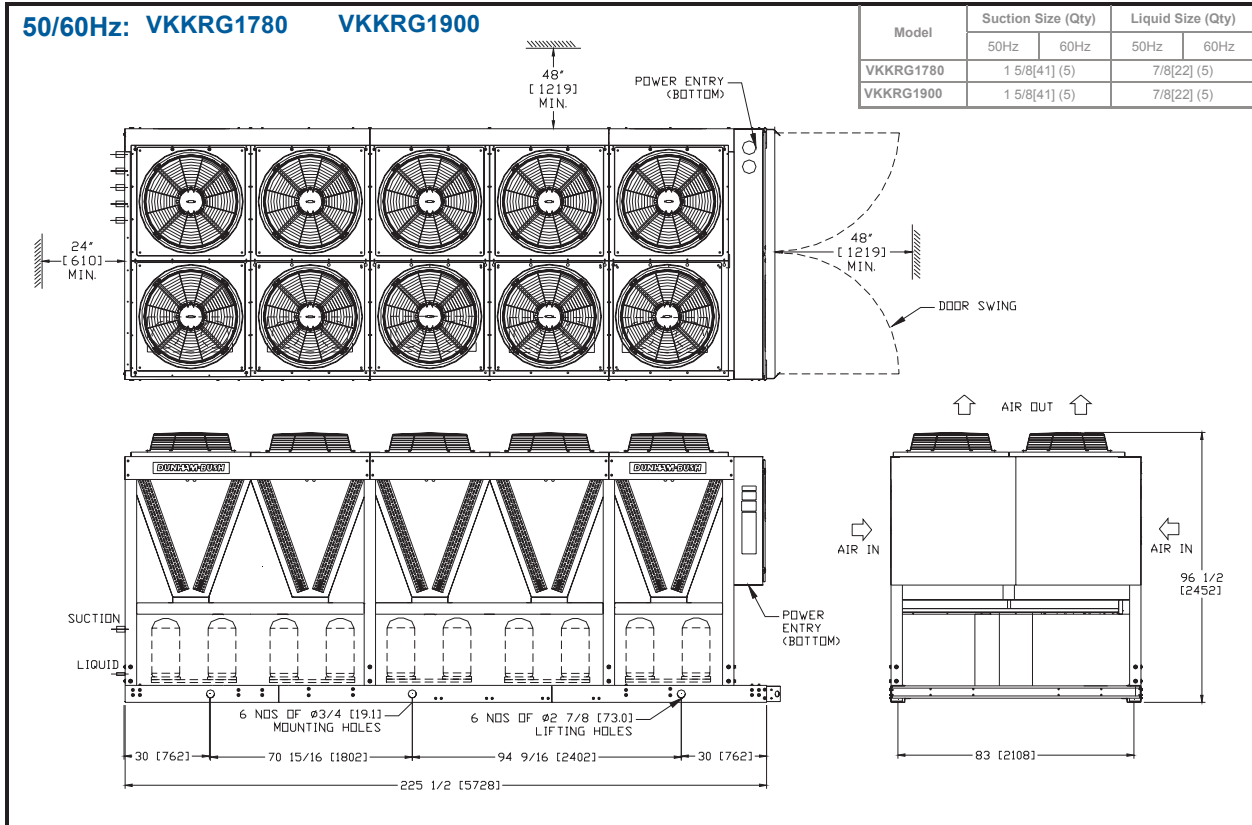
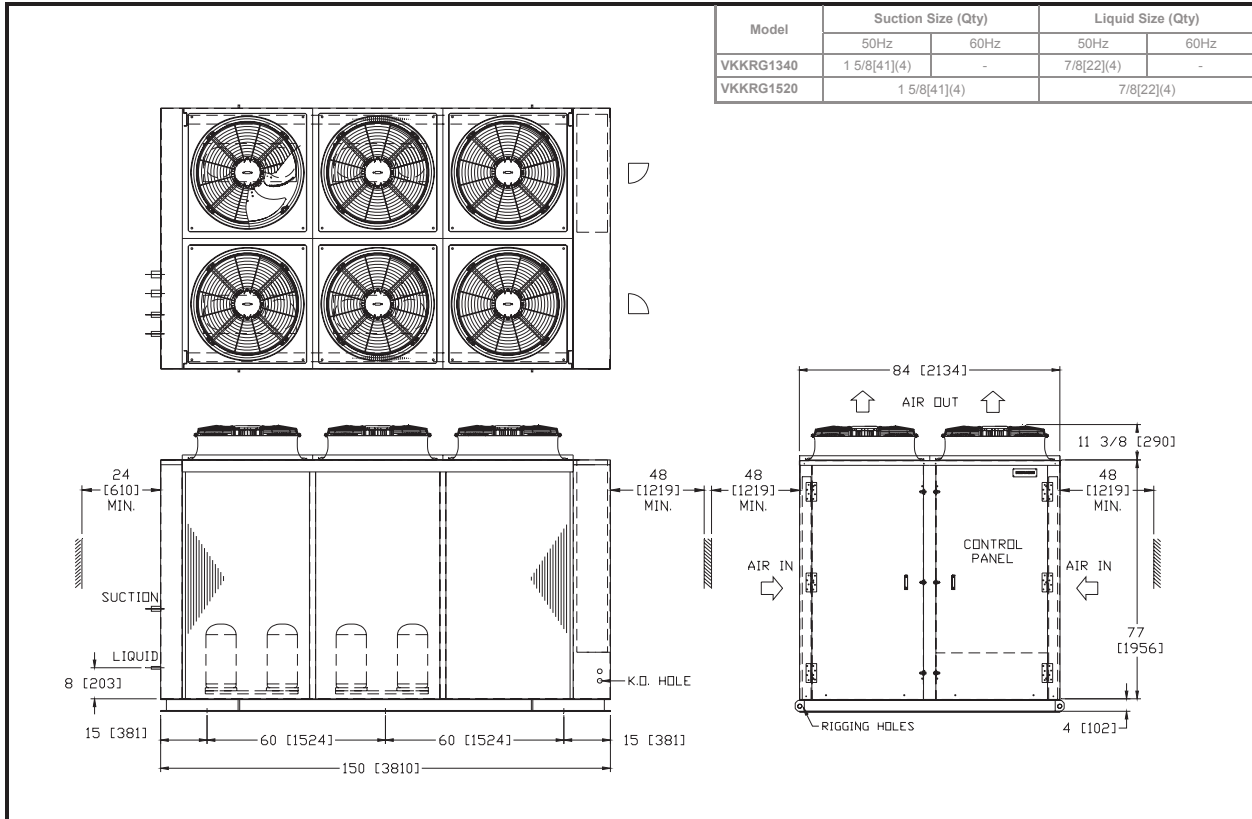

Note: All dimensions are in inches [mm].